

Proiettori lineari e di potenza da 3 a 30 led, da 1 e 2 watt, a basso consumo, atti per rivestire facciate di abitazioni e palazzi, anche di grandi dimensioni. Si tratta di valorizzare architetture tipiche od offrire a quelle più tradizionali una veste originale.

Linear and powerful 3 to 30 leds, 1 and 2 watt energy-saving spotlights, capable of illuminating the front of particularly large homes and buildings. The aim is to set off typical architecture and offer an original appearance for more traditional styles.

Projecteurs linéaires, à haute puissance, ayant de 3 à 30 leds, 1 et 2 watts, à faible consommation, adaptés pour illuminer les façades d'habitations ou d'édifices même de grandes dimensions. Il s'agit ici de valoriser des architectures typiques ou bien de donner à celles plus traditionnelles une touche d'originalité.

Proyectores rectos y de potencia de 3 a 30 leds, de 1 y 2 watt, con bajo consumo, adecuados para fachadas de viviendas y palacios, también de grandes dimensiones. Se trata de valorizar arquitecturas típicas u ofrecer a las más tradicionales un aspecto original.

Lineare Scheinwerfer mit einer Leistung von 3 bis 30 LED, von 1 bis 2 Watt und niedrigem Verbrauch sind für die Ausstattung von Haus- und Gebäudefassaden vorgesehen. Dadurch gelingt die Aufwertung typische Architekturformen und die originelle Präsentation traditioneller Bausubstanzen.



Luci dal basso verso l'alto per dare profondità e calore all'ambiente, valorizzando la particolare conformazione del locale. Rabas 3led 2watt wallwasher / Light shines from the bottom and is directed upwards to give the environment depth and warmth, setting off the original structure of the room. Rabas 3 leds 2 watt wall wash / Un éclairage du bas vers le haut pour donner un effet de profondeur et de chaleur à l'ambiance, en valorisant la configuration particulière du local. Rabas 3 leds 2 watts wallwasher / Luces de abajo arriba para conferir profundidad y calor al ambiente, realzando la particular conformación del local. Rabas 3 leds 2 watt wallwasher / Von unten nach oben verlaufende Lichtstrahlen geben dem Ambiente mehr Tiefe und Wärme und unterstreichen die besondere Beschaffenheit des Raums. Rabas 3 led 2 Watt wallwasher

496 | CAP 17



Luci ad effetto per enfatizzare le particolarità della chiesa e permettere una corretta lettura dell'architettura. Lefta 10 led 2 watt bianco freddo / Impressive lights set off the special features of this church and attract attention to the distinguishing architectural elements. Lefta 10 led 2 watt cold white / Un éclairage d'effet pour emphasiser les caractéristiques de l'église et permettre d'observer toutes ses caractéristiques architecturales. Lefta 10 led 2 watt blanc froid / Luces de efecto para enfatizar la peculiaridad de la iglesia y permitir la correcta lectura de la arquitectura. Lefta 10 led 2 watt blanco frío / Effektbeleuchtung, um die Besonderheiten der Kirche zu betonen und eine korrekte Deutung der Architektur zu ermöglichen. Lefta 10 led 2 watt Kaltweiß.



Per chiese e monumenti, attraverso un'adeguata illuminazione si tutela nel contempo sia la spiritualità del luogo che la fruizione e la conservazione delle opere d'arte.

Progetto: Johanneskirche - Dusseldorf
Lighting Design: W. Rabe

Prodotti: Lefta 10 led 2 Watt
Bianco caldo

Suitable lighting for churches and monuments protects both the spirituality of the building and the use and conservation of the works of art.

Project: Johanneskirche - Dusseldorf
Lighting Design: W. Rabe

Products used: Lefta 10 leds 2 watt
Warm white

En ce qui concerne les églises et les monuments, grâce à un éclairage approprié, on respecte la spiritualité du lieu tout en protégeant la jouissance et la conservation des œuvres d'art.

Projet: Johanneskirche - Dusseldorf
Design éclairage: W. Rabe

Produits: Lefta 10 leds 2 watts
Blanc chaud

Para iglesias y monumentos, mediante la iluminación adecuada se tutela al mismo tiempo la espiritualidad del lugar y el uso y la conservación de las obras de arte.

Proyecto: Johanneskirche - Dusseldorf
Lighting Design: W. Rabe

Productos: Lefta 10 leds 2 watt
blanco cálido

Bei Kirchen und Baudenkmäler werden durch eine angemessene Beleuchtung sowohl die Spiritualität des Orts als auch die Nutzbarkeit und der Erhaltung der Kunstwerke gewährleistet.

Projekt: Johanneskirche - Düsseldorf
Lighting Design: W. Rabe

Produkte: Lefta 10 led 2 Watt
Warmweiß

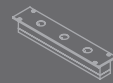

OUTSIDE floor

Rabas

- living outside

Rabas

Profilo rettangolare fisso carrabile per esterni. Applicazione con controcassa. Corpo in alluminio.

Rectangular fixed outdoor drive-over section. Aluminium frame fixable with brackets in Al/SI 304 (to order separately).

Règlette rectangulaire fixe à encastrer au sol pour extérieur Application avec boîtier d'encastrer. Corps en Aluminium.

Perfil rectangular fijo transitable para exterior. Aplicación con contracaja. Cuerpo en aluminio.

Fahrbares festes rechteckiges Profil für Außenräume. Anbringung mit Montagegehäuse. Gehäuse aus Aluminium.



Driver NON compreso

Driver not included
Driver non compris
Driver no incluido
exklusive Driver

vedi cap. Driver
See Driver section
Voir chapitre Drivers
Ver capitulo Driver
siehe Kap. "Driver"

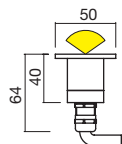
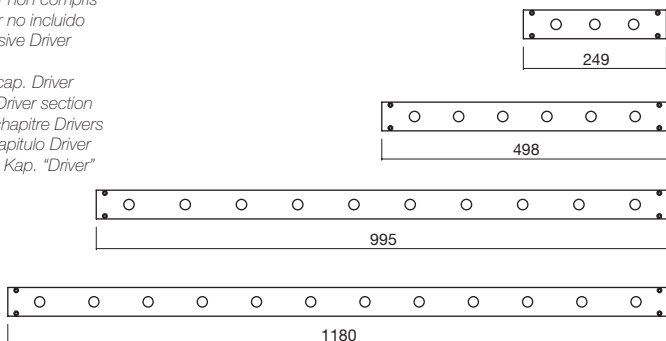

2000 Kg



3 mt

45°



350mA

600 mA



0,920

1,650

3,000

3,600

Colours

Opticals code



84919

Controcassa
Outercasing
Boitier
Contracaja
Einbangehäuse



84920

Controcassa
Outercasing
Boitier
Contracaja
Einbangehäuse



87921

Controcassa
Outercasing
Boitier
Contracaja
Einbangehäuse



87922

Controcassa
Outercasing
Boitier
Contracaja
Einbangehäuse

- C
- W
- N
- B
- Y
- R
- G

- 10° **10**
- 30° **30**
- 50° **50**
- 70° **70**
- 120° **12**
- Wall Washer 25° **25**

CAP 17 | 499

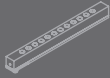

Areno



Areno

Perfil rectangular orientable para exterior. Cuerpo en aluminio. Fijación con tijas en acero AISI 304 suministradas a parte.

Ausrichtbares rechteckiges Profil für Außenräume. Gehäuse aus Aluminium. Befestigung mit Bügeln aus Stahl AISI304, die separat zu bestellen sind.

Profilo rettangolare orientabile per esterni. Corpo in alluminio. Fissaggio con staffe in acciaio AISI304 da ordinare separatamente.

Rectangular and adjustable outdoor section. Aluminium frame fixable with brackets in AISI 304 (to order separately).

Réglette rectangulaire orientable pour extérieur. Corps en Aluminium. Fixation avec étrier AISI304 a commander séparément

2 Watt

G	86822	12 LED
G	86823	18 LED

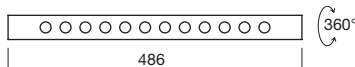

Driver NON compreso

Driver not included
Driver non compris
Driver no incluido
exklusive Driver

vedi cap. Driver
See Driver section
Voir chapitre Drivers
Ver capitolo Driver
siehe Kap. "Driver"

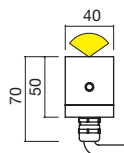

600mA **2 WATT POWER**

Opticals	code	Colours
10°	10	C
30°	30	W
50°	50	N
70°	70	B
120°	12	Y
Wall Washer 25°	25	R
		G



87022
Optional

87020
Optional

87019
Optional

87017
Optional



La tecnologia LED controllata dal protocollo DMX permette di risaltare attraverso studiati effetti dinamici le particolarità architettoniche dell'imponente struttura.

Progetto: Ponte de "La Salve", Bilbao, Spain
 Artist: Daniel Buren
 Lighting specialist: Susaeta Prolighting Bilbao

Products: n. 655 Lefta 12 led 2 Watt

The LED technology controlled by the DMX protocol makes it possible to bring out the particular architectural features of the imposing building through carefully designed dynamic effects.

Project: Bridge "La Salve", Bilbao, Spain
 Artist: Daniel Buren
 Lighting specialist: Susaeta Prolighting Bilbao

Products used: n. 655 Lefta 12 led 2 Watt

La technologie à LEDs contrôlée par le protocole DMX permet de mettre en valeur, moyennant la mise au point d'effets dynamiques ad hoc, les caractéristiques architectoniques de cette imposante structure.

Projet: Pont "La Salve", Bilbao, Spain
 Artist: Daniel Buren
 Lighting specialist: Susaeta Prolighting Bilbao

Produits: n. 655 Lefta 12 led 2 Watt

La tecnología LED controlada por el protocolo DMX permite acentuar mediante efectos dinámicos estudiados las características arquitectónicas de la imponente estructura.

Proyecto: Puente "La Salve", Bilbao, Spain
 Artist: Daniel Buren
 Lighting specialist: Susaeta Prolighting Bilbao

Productos: n. 655 Lefta 12 led 2 Watt

Die Technologie LED, die durch das Protokoll DMX kontrolliert wird, ermöglicht die Herausstellung der architektonischen Besonderheiten der mächtigen Struktur durch dynamische Effekte.

Projekt: Brücke "La Salve", Bilbao, Spain
 Artist: Daniel Buren
 Lighting specialist: Susaeta Prolighting Bilbao

Produkte: n. 655 Lefta 12 led 2 Watt



Rabal



Perfil rectangular fijo
transitable para exterior.
Aplicación con contracaja.
Cuerpo en aluminio.

Fahrbares festes
rechteckiges Profil für
Außenräume. Anbringung
mit Montagegehäuse.
Gehäuse aus Aluminium.

Rabal

Profilo rettangolare
fisso carrabile per
esterni. Applicazione
con controcassa.
Corpo in alluminio.

Rectangular fixed outdoor
drive-over section.
Aluminium frame fixable
with brackets in AISI 304
(to order separately).

Réglette rectangulaire fixe
à encastrer au sol pour
extérieur Application avec
boîtier d'encastrer. Corps
en Aluminium.

2 Watt

G	86826	12 LED
G	86827	18 LED

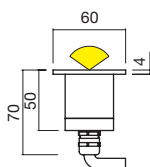
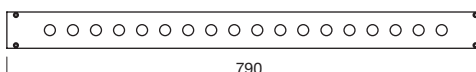
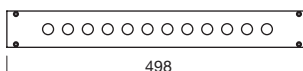

Driver **NON** compreso

Driver not included
Driver non compris
Driver no incluido
exklusive Driver

vedi cap. Driver
See Driver section
Voir chapitre Drivers
Ver capitolo Driver
siehe Kap. "Driver"

600mA 2 WATT POWER, 2,350 3,560, 45°, 3 mt, 2000 Kg, and various safety and certification icons.

Opticals	code	Colours
10°	10	C
30°	30	W
50°	50	N
70°	70	B
120°	12	Y
Wall Washer 25°	25	R
		G

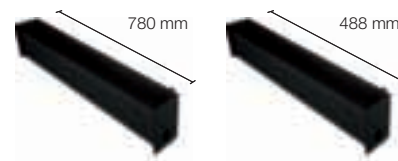

84941
Controcassa
Outercasing
Boîtier
Contracaja
Einbangehäuse

84940
Controcassa
Outercasing
Boîtier
Contracaja
Einbangehäuse

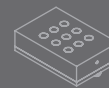

ceiling | wall | floor

OUTSIDE

Barret

Barret

Proiettore a led rettangolare orientabile per esterni. Corpo in alluminio. Fissaggio con staffe in acciaio AISI304 da ordinare separatamente.

Outdoor adjustable rectangular projector on base. Full aluminium. Fixing with brackets in AISI 304 (to order separately).

Projecteur a Led rectangulaire pour extérieur. Corps en Aluminium. Fixation avec étrier en AISI304 a commander séparément

Proyector de leds rectangular, orientable con base para exterior. Cuerpo en aluminio. Fijación con tijas en acero AISI304 suministradas a parte.

Ausrichtbare rechteckige Led-Leuchte für Außenräume Gehäuse aus Aluminium. Befestigung mit Bügeln aus Stahl AISI304, die separat zu bestellen sind.



Driver NON compreso

Driver not included
Driver non compris
Driver no incluido
exklusive Driver

vedi cap. Driver
See Driver section
Voir chapitre Drivers
Ver capitolo Driver
siehe Kap. "Driver"

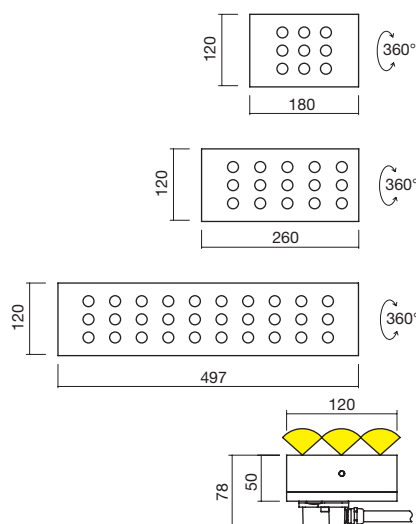

2 Watt

9 LED	86831	G
15 LED	86832	G
30 LED	86833	G



87019
Optional



87020
Optional

Colours	Opticals	code
C	10°	10
W	30°	30
N	50°	50
B	70°	70
Y	120°	12
R	Wall Washer 25°	25
G		

- living outside





Bardir



Bardir

Proyector de leds orientable con base para exterior. Aparato hecho enteramente en aluminio barnizado.

Ausrichtbare Led-Leuchte für Außenräume auf Basis. Leuchte ganz aus lackiertem Aluminium.

Proiettore a led orientabile per esterni su base. Apparecchio interamente in alluminio verniciato.

Outdoor adjustable projector on base. Full painted aluminium.

Profil rectangulaire fixe au sol pour extérieur. Appareil entièrement en Aluminium vernis.

2 Watt

G	87014	9 LED
G	87015	15 LED
G	87016	30 LED

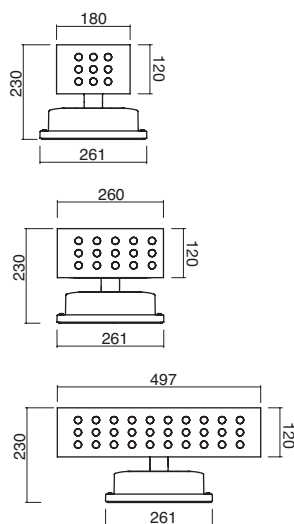

Driver compreso

*Driver included
Driver compris
Driver incluido
inklusive Driver*

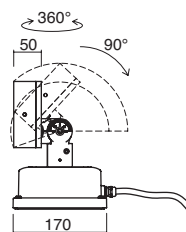

600mA **2 WATT POWER**

Opticals	code	Colours
10°	10	C
30°	30	W
50°	50	N
70°	70	B
120°	12	Y
Wall Washer 25°	25	R G

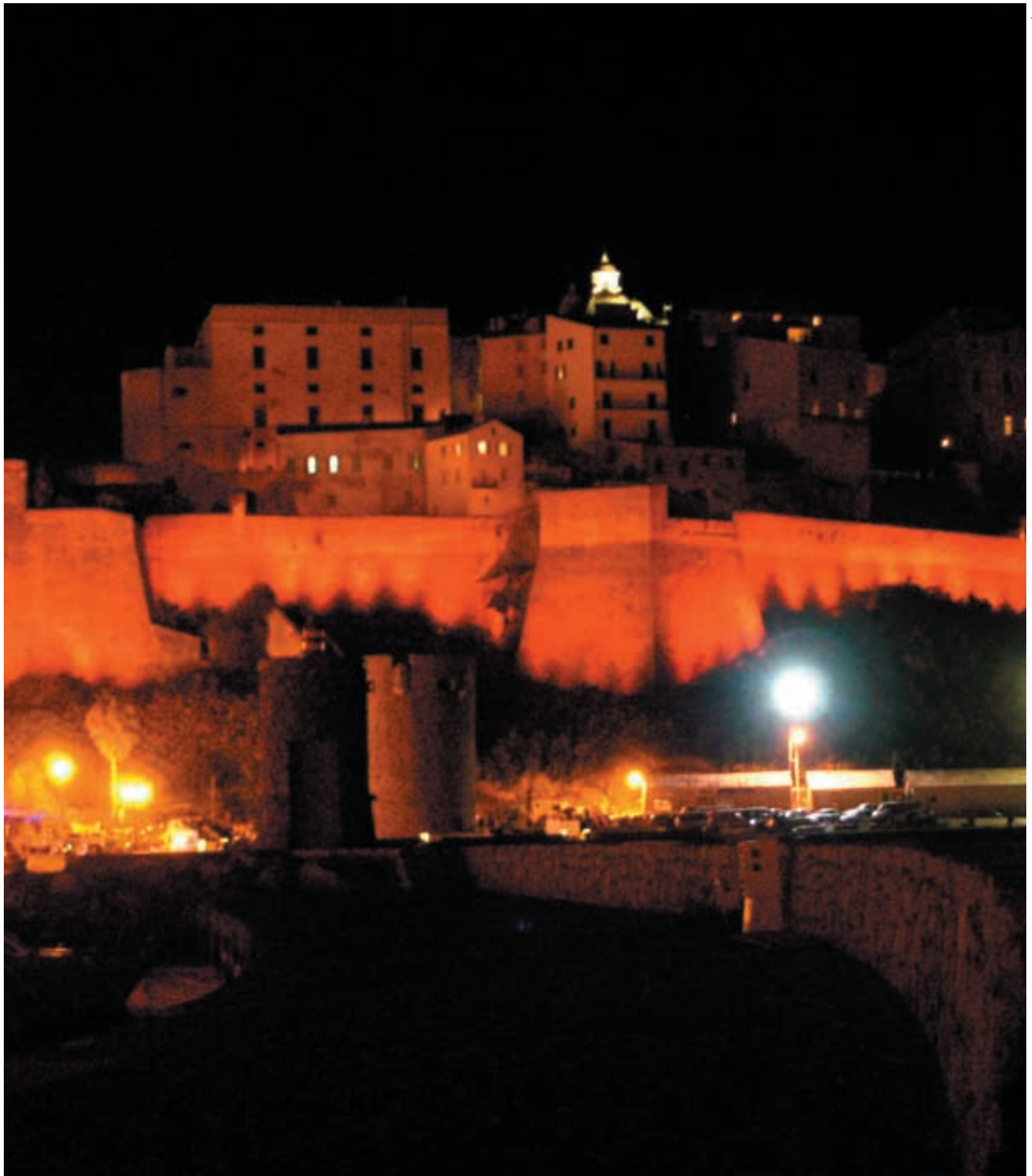

Il perimetro della Cittadella
delineato da proiettori di potenza.

*The perimeter of Cittadella is
marked off by powerful spotlights.*

*Le pourtour de Cittadella est tracé
par de puissants projecteurs.*

*El perímetro de la Cittadella
perfilado por proyectores de
potencia.*

*Der Umfang der Cittadella
wird durch starke Scheinwerfer
hervorgehoben.*

Progetto: Calvi, Corsica
Lighting Design: Corsalux

*Project: Calvi, Corsica
Lighting Design: Corsalux*

*Projet: Calvi, Corse
Design éclairage: Corsalux*

*Proyecto: Calvi - Córcega
Lighting Design: Corsalux*

*Projekt: Calvi, Korsika
Lighting Design: Corsalux*

Prodotti: Bardir 2 Watt 15 Led

Products used: Bardir 2 Watt 15 Led

Produits: Bardir 2 Watt 15 Led

Productos: Bardir 2 Watt 15 Led

Produkte: Bardir 2 Watt 15 Led

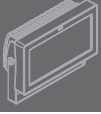

New Farled



New Farled

Proiettore orientabile.
Struttura in alluminio
pressofuso. Diffusore in
vetro temprato. Possibilità
di fissaggio con staffa o
con picchetto.

Adjustable projector,
aluminium Pressure die-
casting case and tempered
glass diffuser. Fixable with
bracket or picket.

Projecteur orientable.
Structure en Aluminium
(Moulage sous pression),
diffuseur en verre trempé.
Possibilité de fixation
avec étrier ou à
l'aide d'un piquet.

Proyector orientable.
Estructura en fundición a
presión de aluminio. Difusor
en cristal templado. Sistema
de fijación con tijas o con
piquete.

Ausrichtbare
Leuchte. Struktur aus
Druckgussaluminium.
Lichtdiffusor aus
vorgespanntem Glas.
Befestigungsmöglichkeit mit
Bügeln oder Pflock.

Driver NON compreso

Driver not included
Driver non compris
Driver no incluido
exklusive Driver

vedi cap. Driver
See Driver section
Voir chapitre Drivers
Ver capitolo Driver
siehe Kap. "Driver"

		2 Watt
picket optional		12 LED
84882	G	87264
		2 Watt
picket optional		21 LED
84882	G	87274
		2 Watt
	G	30 LED
		87911

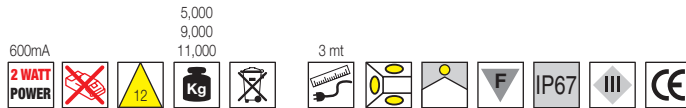
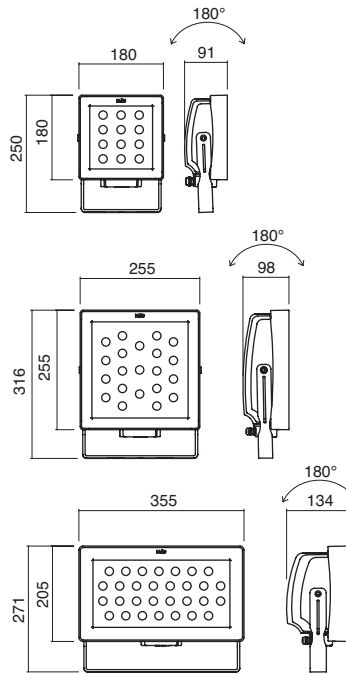

Opticals	code	Colours
10°	10	● C
30°	30	● W
50°	50	○ N
70°	70	● B
120°	12	● Y
Wall Washer 25°	25	● R
		● G



84882
Sistema di fissaggio
con picchetto
Fixing system with picket.
Système de fixation avec
piquet en acier
Sistema de instalacion con piqueta
Erdspließbefestigung



New Farled

Proiettore orientabile.
Struttura in alluminio
pressofuso. Diffusore in
vetro temprato. Possibilità
di fissaggio con staffa,
con base o con picchetto.

Adjustable projector, aluminium
Pressure die-casting case
and tempered glass diffuser.
Fixable with bracket,
base or picket.

Projecteur orientable.
Structure en Aluminium
(Moulage sous pression),
diffuseur en verre trempé.
Possibilité de fixation avec
étrier, base ou à l'aide
d'un piquet.

Proyector orientable.
Estructura en fundición a
presión de aluminio.
Difusor en cristal templado.
Sistema de fijación con tijas,
con base o con piqueta.

Ausrichtbare
Leuchte. Struktur aus
Druckgussaluminium.
Lichtdiffusor aus
vorgespanntem Glas.
Befestigungsmöglichkeit mit
Bügeln, Basis oder Pflock.

Driver compreso

Driver included
Driver compris
Driver incluido
inklusive Driver

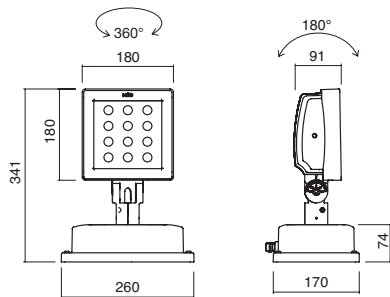
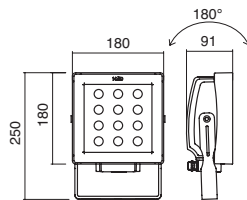

2 Watt

12 LED

optional

87265

G

84882

Con driver
Driver included / Driver compris / Driver incluido / inklusive Driver

87266

G

84882

Con driver dimmerabile
Dimmerable driver
Alimentateur à l'intérieur
Alimentador interior dimmerable
Internes Netzteil

2 Watt

12 LED

87271

G

Con driver
Driver included / Driver compris / Driver incluido / inklusive Driver

87272

G

84983

Con driver dimmerabile controllo IR sul faro
Dimmerable driver with IR control on the spot light
Alimentateur avec gradateur et contrôle IR sur le spot
Alimentador dimmerable con control IR en el foco
Netzteil mit dimmer mit IR Kontrolle auf der Leuchte

87273

G

84841
84983

Con driver dimmerabile
Dimmerable driver
Alimentateur à l'intérieur
Alimentador interior dimmerable
Internes Netzteil

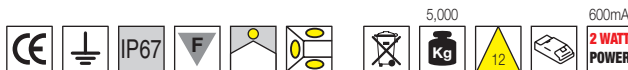

84882

Sistema di fissaggio
con picchetto
Fixing system with picket.
Système de fixation avec
piquet en acier
Sistema de instalacion con piqueta
Erdspießbefestigung



84841

optional



84983

optional

Colours

- C
- W
- N
- B
- Y
- R
- G

Opticals code

- 10° **10**
- 30° **30**
- 50° **50**
- 70° **70**
- 120° **12**
- Wall Washer 25° **25**





New Farled



New Farled

Proyector orientable.
Estructura en fundición a presión de aluminio.
Difusor en cristal templado.
Sistema de fijación con tijas, con base o con piqueta.

Proiettore orientabile.
Struttura in alluminio pressofuso.
Diffusore in vetro temprato.
Possibilità di fissaggio con staffa, con base o con picchetto.

Ausrichtbare Leuchte. Struktur aus Druckgussaluminium.
Lichtdiffusor aus vorgespanntem Glas.
Befestigungsmöglichkeit mit Bügeln, Basis oder Pflock.

Adjustable projector, aluminium Pressure die-casting case and tempered glass diffuser. Fixable with bracket, base or picket.

Projecteur orientable. Structure en Aluminium (Moulage sous pression), diffuseur en verre trempé.
Possibilité de fixation avec étrier, base ou à l'aide d'un piquet.

2 Watt

optional

21 LED

Con driver / Driver included / Driver compris / Driver incluido / inklusive Driver
84882 G 87275

Con driver dimmerabile / Dimmerable driver / Alimentateur à l'intérieur / Alimentador interior dimerable / Internes Netzteil
84882 G 87276
84983

2 Watt

21 LED

Con driver / Driver included / Driver compris / Driver incluido / inklusive Driver
G 87281

Con driver dimmerabile controllo IR sul fano / Dimmerable driver with IR control on the spot light / Alimentateur avec gradateur et contrôle IR sur le spot / Alimentador dimerable con control IR en el foco / Netzteil mit dimmer mit IR Kontrolle auf der Leuchte
84983 G 87909

Con driver dimmerabile / Dimmerable driver / Alimentateur à l'intérieur / Alimentador interior dimerable / Internes Netzteil
84841 G 87910
84983

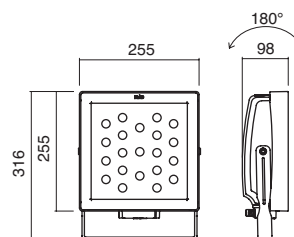

Driver compreso

Driver included / Driver compris / Driver incluido / inklusive Driver

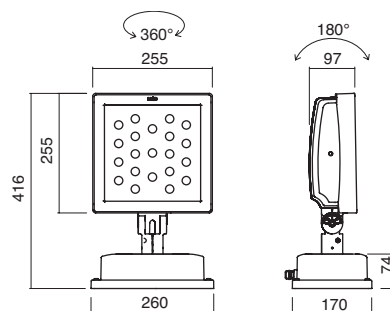

Opticals	code	Colours
10°	10	C
30°	30	W
50°	50	N
70°	70	B
120°	12	Y
Wall Washer 25°	25	R
		G



84983 optional



84841 optional



84882 Sistema di fissaggio con picchetto / Fixing system with picket / Système de fixation avec piquet en acier / Sistema de instalacion con piqueta / Erdspießbefestigung



OUTSIDE ceiling

New Farled

Proiettore orientabile.
Struttura in alluminio
pressofuso. Diffusore
in vetro temprato.
Possibilità di fissaggio
con staffa o con base.

Adjustable projector,
aluminium Pressure die-
casting case and tempered
glass diffuser. Fixable with
bracket or base.

Projecteur orientable.
Structure en Aluminium
(Moulage sous pression),
diffuseur en verre trempé.
Possibilité de fixation
avec étrier ou base.

Proyector orientable.
Estructura en fundición
a presión de aluminio.
Difusor en cristal templado.
Sistema de fijación
con tijas o con base.

Ausrichtbare
Leuchte. Struktur aus
Druckgussaluminium.
Lichtdiffusor aus
vorgespanntem Glas.
Befestigungsmöglichkeit mit
Bügeln oder mit Basis.



Driver compreso

Driver included
Driver compris
Driver incluido
inklusive Driver

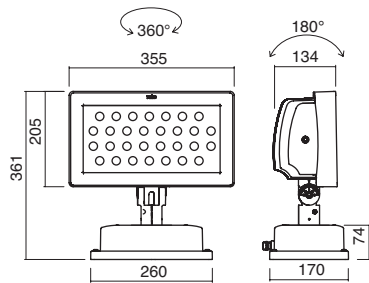
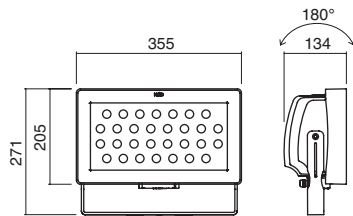

2 Watt

30 LED

optional

87912

G

Con driver
Driver included / Driver compris / Driver incluido / inklusive Driver

87914

G

84841
84983

Con driver dimmerabile
Dimmerable driver
Alimentateur à l'intérieur
Alimentador interior dimmerable
Internes Netzteil

2 Watt

30 LED

87915

G

Con driver
Driver included / Driver compris / Driver incluido / inklusive Driver

87916

G

84983

Con driver dimmerabile controllo IR sul faro
Dimmerable driver with IR control on the spot light
Alimentateur avec gradateur et contrôle IR sur le spot
Alimentador dimmerable con control IR en el foco
Netzteil mit dimmer mit IR Kontrolle auf der Leuchte

87917

G

84841
84983

Con driver dimmerabile
Dimmerable driver
Alimentateur à l'intérieur
Alimentador interior dimmerable
Internes Netzteil

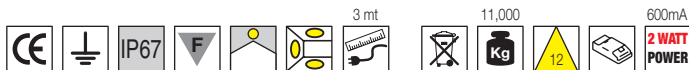

84841
optional



84983
optional

Colours

Opticals code

- C
- W
- N
- B
- Y
- R
- G

- 10° **10**
- 30° **30**
- 50° **50**
- 70° **70**
- 120° **12**
- Wall Washer 25° **25**

New Farled

- living outside



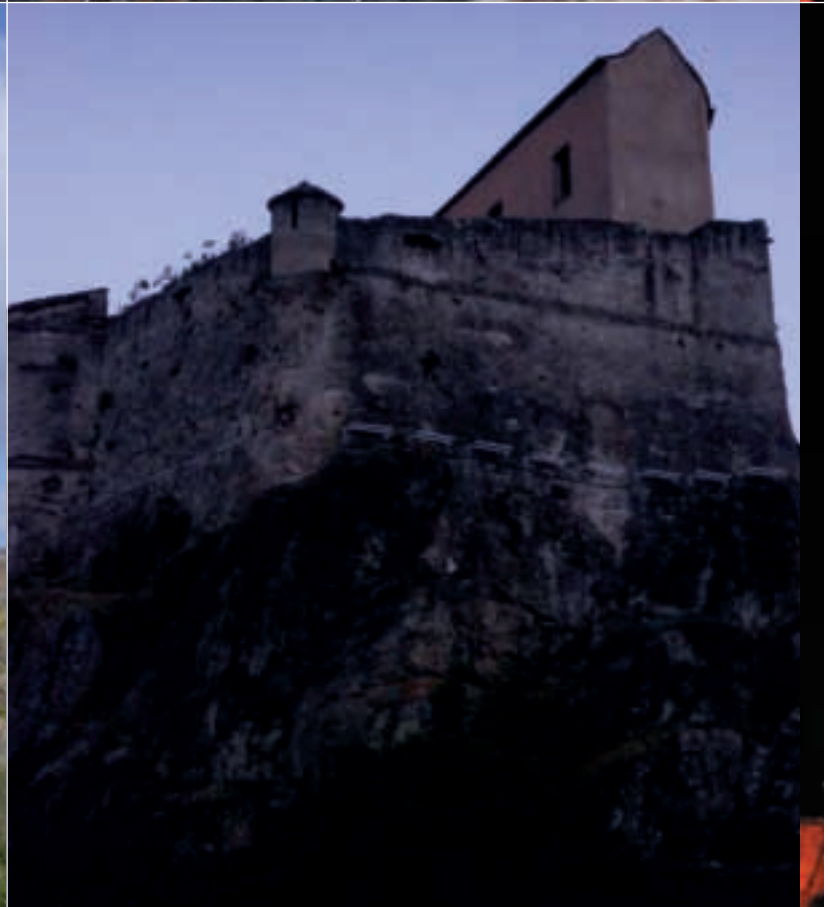
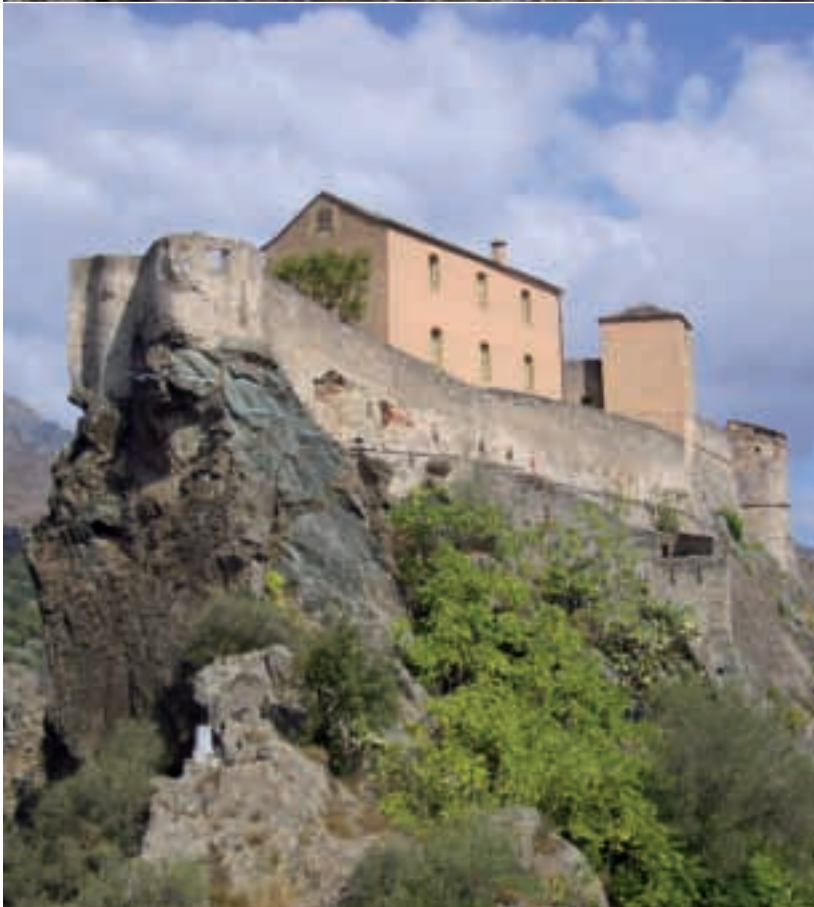
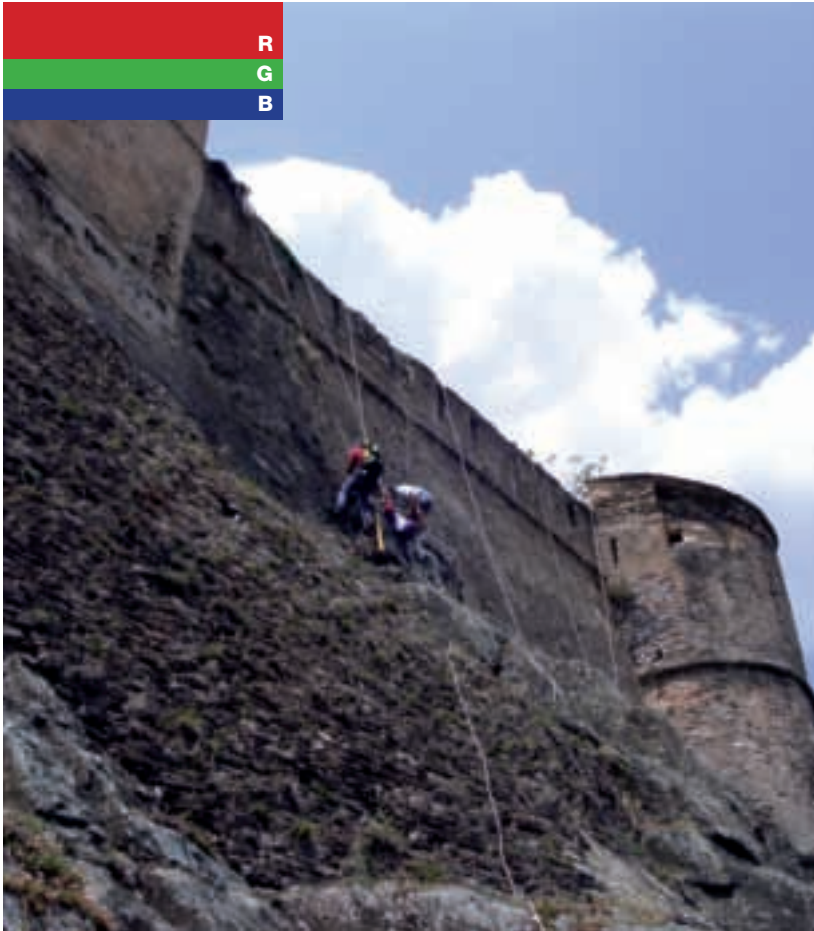

Fasi d'installazione dei proiettori lineari. La facilità dei collegamenti aiuta la difficile posizione del personale qualificato per questo progetto di altissimo livello.

Installation of in-line spotlights. The difficult position of the qualified personnel is alleviated by the easy connection method used for this impressive project.

Les différentes étapes d'installation des projecteurs linéaires. La simplicité des raccordements facilite les opérations du personnel se trouvant dans des positions difficiles pour la mise en œuvre de ce projet de très haut niveau.

Fases de instalación de los proyectores rectos. La sencillez de las conexiones ayuda la difícil posición del personal cualificado para este proyecto de altísimo nivel.

Installation von linearen Scheinwerfern. Die mühelose Herstellung der Anschlüsse erleichtert die Arbeit des Fachpersonals, das speziell für dieses Projekt höchsten Niveaus ausgebildet wurde.

Progetto: Cittadelle Corte - Corsica - France
Lighting Design: Corsalux

Project: Cittadelle Corte - Corsica - France
Lighting Design: Corsalux

Projet: Cittadelle Corte - Corse - France
Design éclairage: Corsalux

Proyecto: Cittadelle Corte - Córcega - Francia
Lighting Design: Corsalux

Projekt: Zitadelle von Corte - Korsika - Frankreich
Lighting Design: Corsalux

Prodotti: Remur 12 led 2watt RGB

Products used: Remur 12 leds 2 watt RGB

Produits: Remur 12 leds 2 watt RGB

Productos: Remur 12 leds 2 watt RGB

Produkte: Remur 12 LED 2 Watt RGB

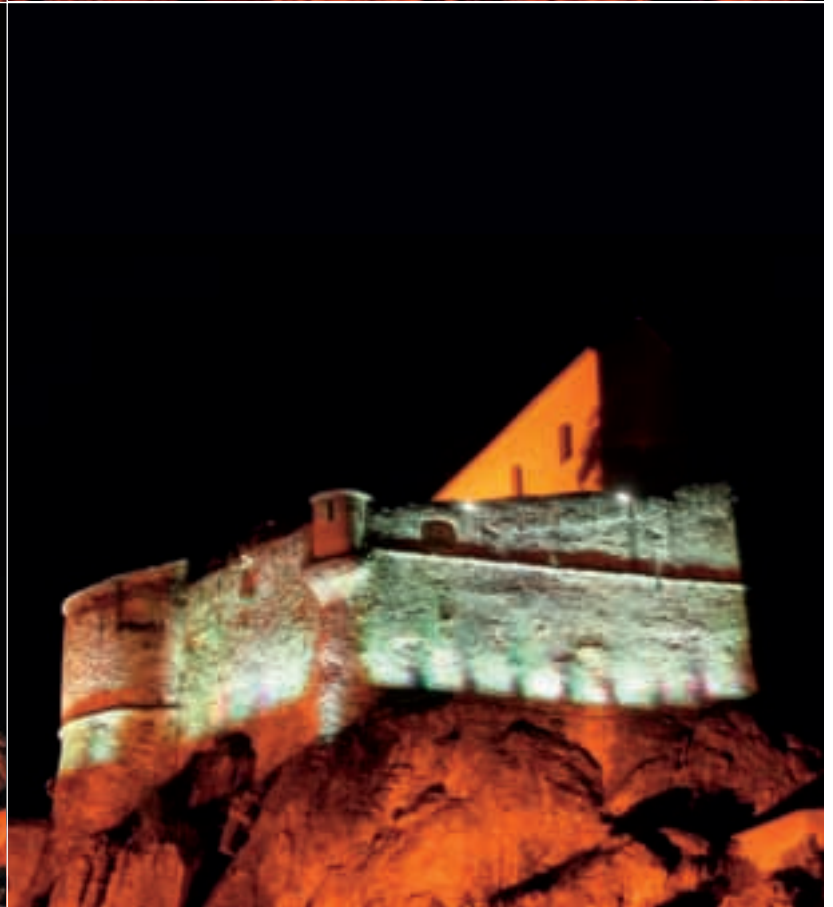
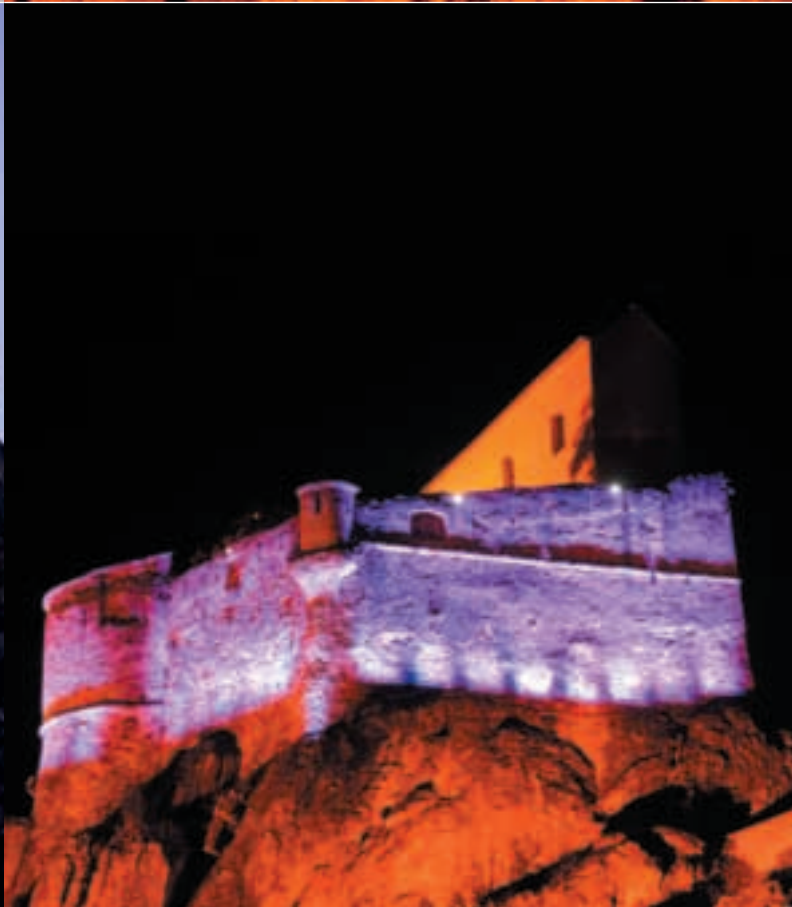
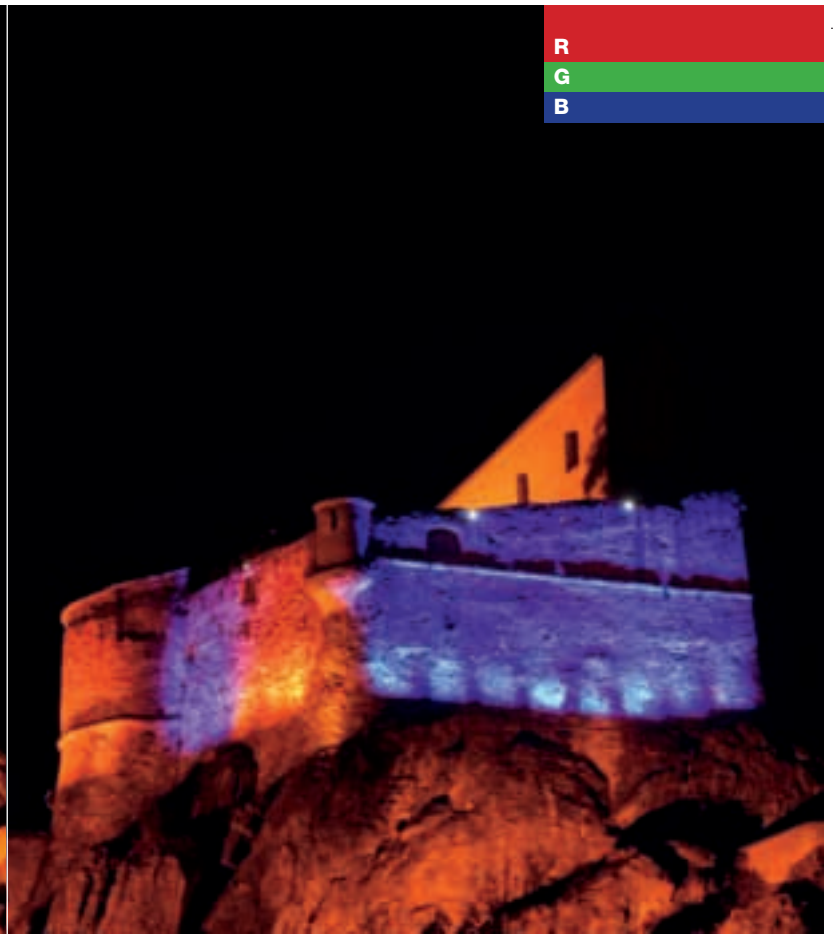
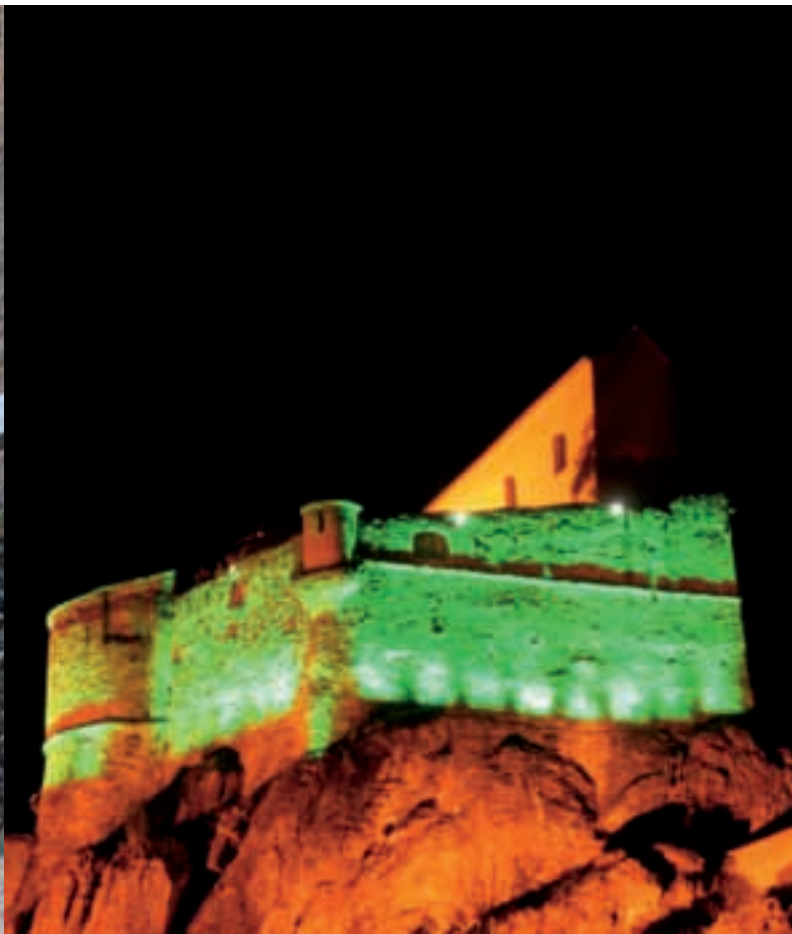

Connubio tra tecnologia e storia: è il momento dello spettacolo dell'architettura. Le mura storiche hanno un'altezza di circa 10 metri.

A blend of technology and history to stage architecture. The historical walls are about 10 metres high.

L'alliance technologie-histoire: c'est le moment du spectacle de l'architecture. Les anciennes murailles ont une hauteur d'environ 10 mètres.

Combinación de historia y tecnología: es la hora del espectáculo de la arquitectura. Los muros históricos son de unos 10 metros de alto.

Eine gelungene Verbindung zwischen Technologie und Geschichte: Architektur wird zum eindrucksvollen Schauspiel. Die alten Wehmauern haben eine Höhe von zirka 10 Metern.

Progetto: Rocca di Corte - Corsica - France
Lighting Design: Corsalux

*Project: Rocca di Corte - Corsica - France
Lighting Design: Corsalux*

*Projet: Rocca di Corte - Corse - France
Design éclairage: Corsalux*

*Proyecto: Rocca di Corte - Córcega - Francia
Lighting Design: Corsalux*

*Projekt: Rocca von Corte - Korsika - Frankreich
Lighting Design: Corsalux*

Prodotti: Remur 12 led 2watt RGB

Products used: Remur 12 leds 2 watt RGB

Produits: Remur 12 leds 2 watts RGB

Productos: Remur 12 leds 2 watt RGB

Produkte: Remur 12 LED 2Watt RGB

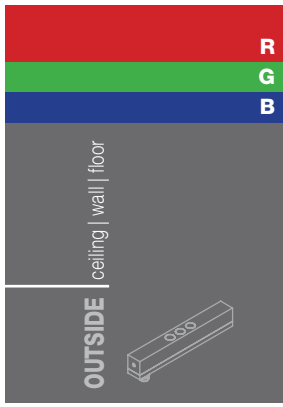

Remur



Perfil rectangular orientable para exterior. Cuerpo en aluminio. Fijación con tijas en acero AISI 304 suministradas a parte.

Ausrichtbares rechteckiges Profil für Außenräume. Gehäuse aus Aluminium. Befestigung mit Bügeln aus Stahl AISI304, die separat zu bestellen sind.

Remur

Profilo rettangolare orientabile per esterni. Corpo in alluminio. Fissaggio con staffe in acciaio AISI304 da ordinare separatamente.

Rectangular and adjustable outdoor section. Aluminium frame fixable with brackets in AISI 304 (to order separately).

Règlette rectangulaire orientable pour extérieur. Corps en Aluminium. Fixation avec étrier en AISI304 à commander séparément

**2 Watt
RGB**

Driver NON compreso

*Driver not included
Driver non compris
Driver no incluido
exklusive Driver*

*vedi cap. Driver
See Driver section
Voir chapitre Drivers
Ver capitulo Driver
siehe Kap. "Driver"*

G	86812	3 LED	
G	86813	6 LED	
G	86814	12 LED	
G	86815	15 LED	

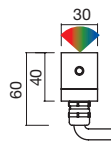

600mA

86814Z25

Opticals code

Colours

Wall Washer 25° 25

Z



87022
Optional

87020
Optional

87019
Optional

87021
Optional

Balmur

Profilo rettangolare
fisso carrabile per
esterni. Applicazione
con controcassa.
Corpo in alluminio.

Rectangular fixed outdoor
drive-over section.
Aluminium frame fixable
with brackets in AISI 304
(to order separately).

Profil rectangulaire fixe
au sol pour extérieur.
Application avec boîtier
d'encastrer.
Corps en Aluminium

Perfil rectangular fijo
transitable para exterior.
Aplicación con contracaja.
Cuerpo en aluminio.

Fahrbares festes
rechteckiges Profil für
Außenräume. Anbringung
mit Montagegehäuse.
Gehäuse aus Aluminium.



Driver NON compreso

Driver not included
Driver non compris
Driver no incluido
exklusive Driver

vedi cap. Driver
See Driver section
Voir chapitre Drivers
Ver capitolo Driver
siehe Kap. "Driver"

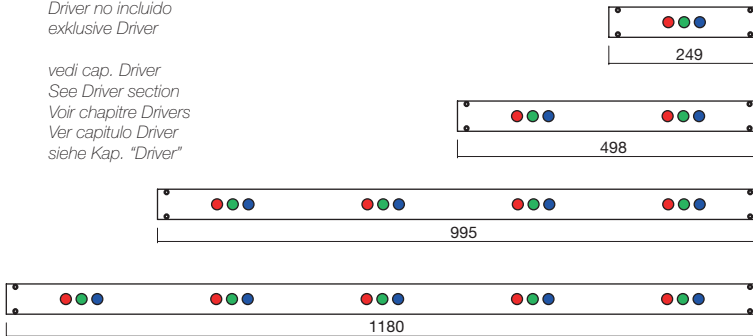

2 Watt
RGB

3 LED	86816	G
6 LED	86817	G
12 LED	86818	G
15 LED	86819	G

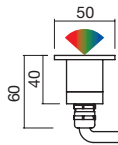

1,500
1,860
2,590
3,200

2000 Kg

Colours Opticals code

RGB Z

Wall Washer 25° 25

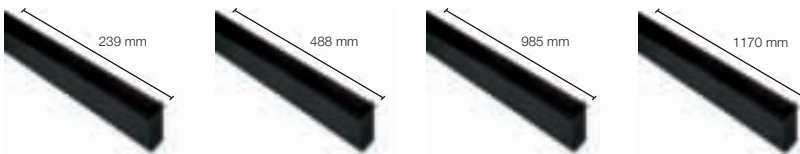

84919
Controcassa
Outercasing
Boîtier
Contracaja
Einbangehäuse

84920
Controcassa
Outercasing
Boîtier
Contracaja
Einbangehäuse

84921
Controcassa
Outercasing
Boîtier
Contracaja
Einbangehäuse

84922
Controcassa
Outercasing
Boîtier
Contracaja
Einbangehäuse

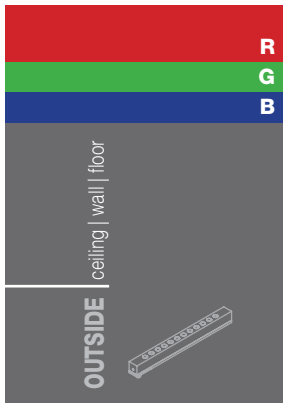

OUTSIDE ceiling | wall | floor

Areno



Areno

Profilo rettangolare orientabile per esterni. Corpo in alluminio. Fissaggio con staffe in acciaio AISI304 da ordinare separatamente.

Rectangular and adjustable outdoor section. Aluminium frame fixable with brackets in AISI 304 (to order separately).

Réglette rectangulaire orientable pour intérieur. Corps en Aluminium. Fixation avec étrier en acier Inox a commander séparément

Perfil rectangular orientable para exterior. Cuerpo en aluminio. Fijación con tijas en acero AISI 304 suministradas a parte.

Ausrichtbares rechteckiges Profil für Außenräume. Gehäuse aus Aluminium. Befestigung mit Bügeln aus Stahl AISI304, die separat zu bestellen sind.

**2 Watt
RGB**

G	86820	12 LED
G	86821	18 LED

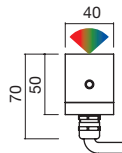
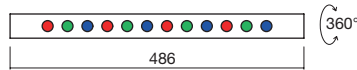

Driver NON compreso

Driver not included
Driver non compresi
Driver no incluido
exklusive Driver

vedi cap. Driver
See Driver section
Voir chapitre Drivers
Ver capitolo Driver
siehe Kap. "Driver"

600mA 2,960 3,450 3 mt

Opticals	code	Colours
----------	------	---------

Wall Washer 25° **25** **Z**



87022
Optional

87020
Optional

87019
Optional

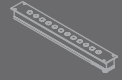

Rabal

Profilo rettangolare
fisso carrabile per
esterni. Applicazione
con controcassa.
Corpo in alluminio.

Rectangular fixed outdoor
drive-over section.
Aluminium frame fixable
with brackets in AISI 304
(to order separately).

Réglette rectangulaire fixe
à encastrer au sol pour
extérieur Application avec
boîtier d'encastrer. Corps
en Aluminium.

Perfil rectangular fijo
transitable para exterior.
Aplicación con contracaja.
Cuerpo en aluminio.

Fahrbares festes
rechteckiges Profil für
Außenräume. Anbringung
mit Montagegehäuse.
Gehäuse aus Aluminium.



Driver NON compreso

Driver not included
Driver non compris
Driver no incluido
exklusive Driver

vedi cap. Driver
See Driver section
Voir chapitre Drivers
Ver capitulo Driver
siehe Kap. "Driver"

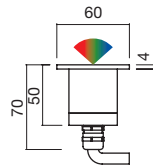
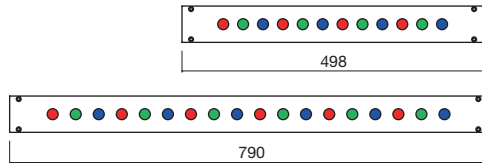

**2 Watt
RGB**

12 LED	86824	G
18 LED	86825	G

Colours Opticals code

Z Wall Washer 25° 25

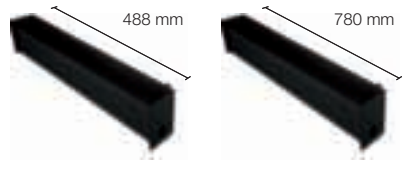

84940
Controcassa
Outercasing
Boîtier
Contracaja
Einbahgehäuse

84941
Controcassa
Outercasing
Boîtier
Contracaja
Einbahgehäuse

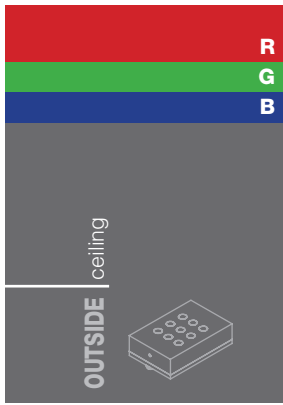

Barret



Barret

Proyector de leds rectangular, orientable con base para exterior. Cuerpo en aluminio. Fijación con tijas en acero AISI304 suministradas a parte.

Proiettore a led rettangolare orientabile per esterni. Corpo in alluminio. Fissaggio con staffe in acciaio AISI304 da ordinare separatamente.

Ausrichtbare rechteckige Led-Leuchte für Außenräume Gehäuse aus Aluminium. Befestigung mit Bügeln aus Stahl AISI304, die separat zu bestellen sind.

Outdoor adjustable rectangular projector on base. Full aluminium. Fixing with brackets in AISI 304 (to order separately).

Projecteur a Led rectangulaire pour extérieur. Corps en Aluminium. Fixation avec étrier en AISI304 a commander séparément

**2 Watt
RGB**

G	86828	9 LED
G	86829	15 LED
G	86830	30 LED

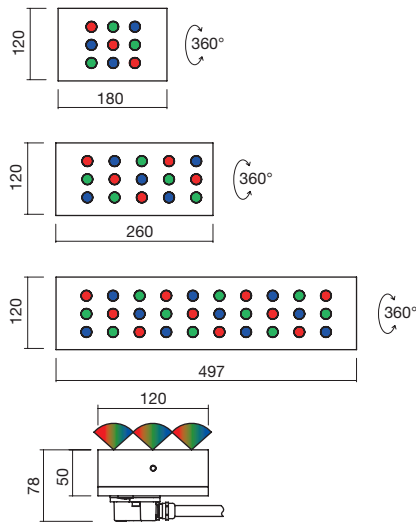

Driver NON compreso

*Driver not included
Driver non compreso
Driver no incluido
exklusive Driver*

*vedi cap. Driver
See Driver section
Voir chapitre Drivers
Ver capitolo Driver
siehe Kap. "Driver"*

86829Z25

600mA 2,350 3 mt

Opticals	code	Colours
Wall Washer 25°	25	Z
50°	50	



87020
Optional

87019
Optional

Bardir

Proiettore a led orientabile per esterni su base. Apparecchio interamente in alluminio verniciato.

Outdoor adjustable projector on base. Full painted aluminium.

Projecteur a Led d'extérieur sur base orientable. Appareil entièrement en Aluminium vernis

Proyector de leds orientable con base para exterior. Aparato hecho enteramente en aluminio barnizado.

Ausrichtbare Led-Leuchte für Außenräume auf Basis. Leuchte ganz aus lackiertem Aluminium.



2 Watt RGB optional

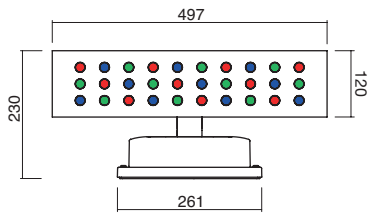
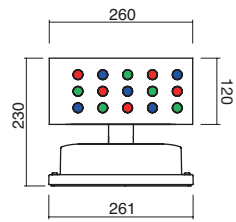
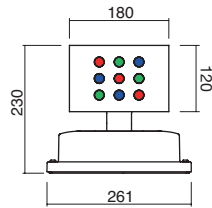
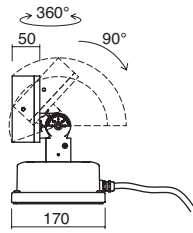

LED Count	Code	Color	Options	Description
9 LED	86837	G		Driver e centralina NON compresi Driver and control unit not included / Driver et central de commande non compris / Driver y controlador no incluido / exklusive Driver und Steuergerät
9 LED	87928	G	84982	CON driver e centralina. Controllo IR sul faro Driver and control included. IR control on the spot light Driver et central de commande compris. Contrôle IR sur le spot Driver y controlador incluido. Control IR en el foco Inklusive Driver und Steuergerät. IR Kontrolle auf der Leuchte
9 LED	87930	G	84982 84841	CON driver e centralina. Driver and control included. / Driver et central de commande compris. Driver y controlador incluido. / Inklusive Driver und Steuergerät.
15 LED	86840	G		Driver e centralina NON compresi Driver and control unit not included / Driver et central de commande non compris / Driver y controlador no incluido / exklusive Driver und Steuergerät
15 LED	86839	G	84982 84841	CON driver e centralina. Controllo IR sul faro Driver and control included. IR control on the spot light Driver et central de commande compris. Contrôle IR sur le spot Driver y controlador incluido. Control IR en el foco Inklusive Driver und Steuergerät. IR Kontrolle auf der Leuchte
15 LED	86838	G		CON driver e centralina. Driver and control included. / Driver et central de commande compris. Driver y controlador incluido. / Inklusive Driver und Steuergerät.
30 LED	87937	G		Driver e centralina NON compresi Driver and control unit not included / Driver et central de commande non compris / Driver y controlador no incluido / exklusive Driver und Steuergerät
30 LED	87933	G	84982	CON driver e centralina. Controllo IR sul faro Driver and control included. IR control on the spot light Driver et central de commande compris. Contrôle IR sur le spot Driver y controlador incluido. Control IR en el foco Inklusive Driver und Steuergerät. IR Kontrolle auf der Leuchte
30 LED	86841	G	84982 84841	CON driver e centralina. Driver and control included. / Driver et central de commande compris. Driver y controlador incluido. / Inklusive Driver und Steuergerät.

Colours	Opticals	code
Z	Wall Washer 25°	25
	50°	50



84841 optional



84982 optional

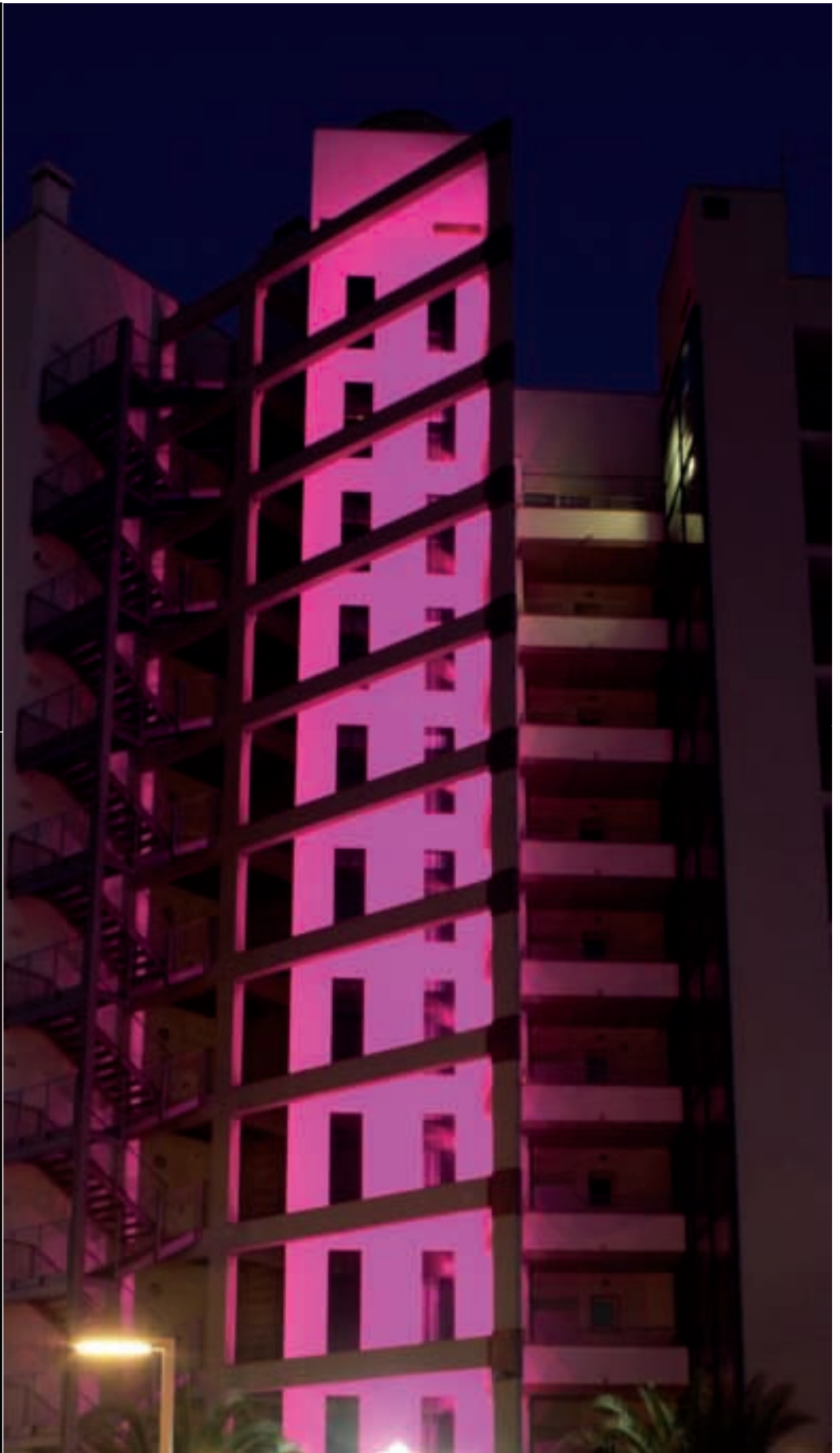
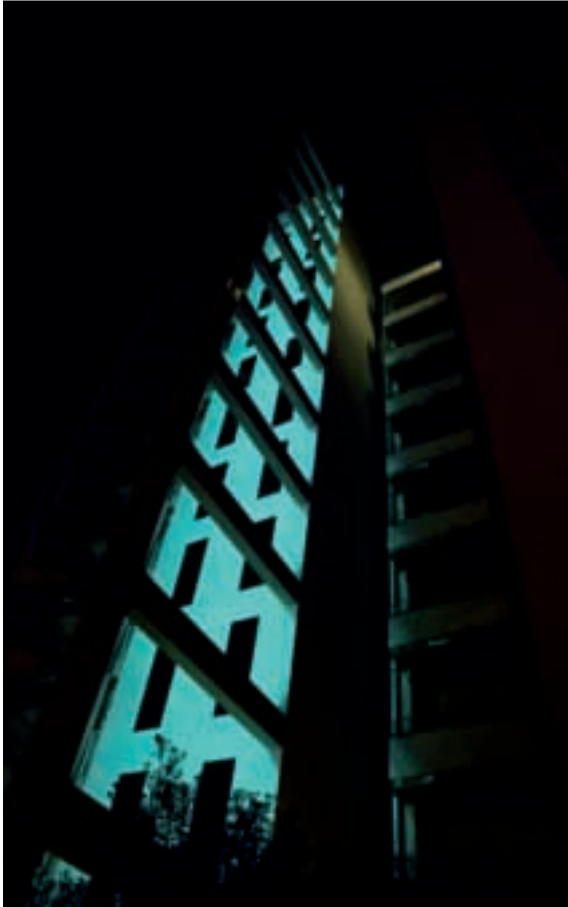
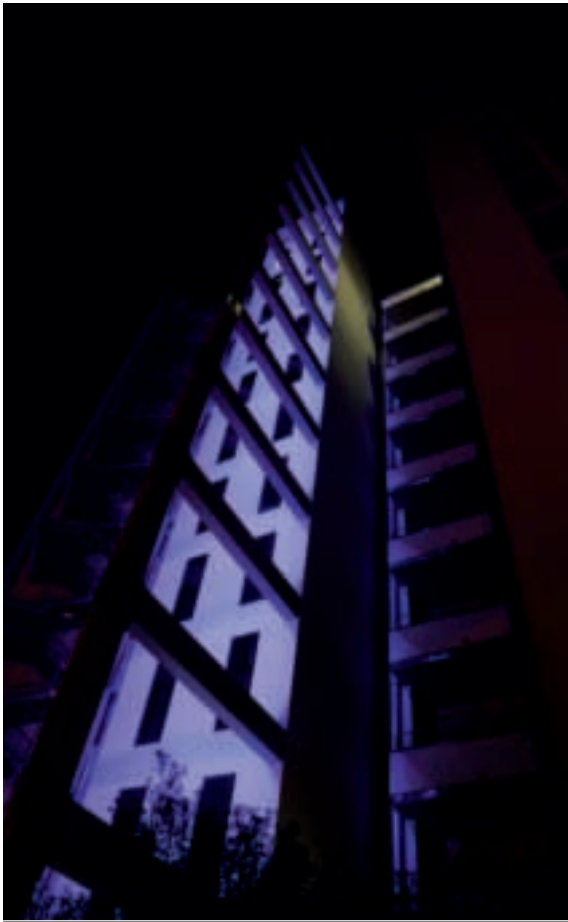

I giochi di colori danno ancor più slancio alla singolare struttura turistica, per differenziarla dal contesto urbano circostante e attrarre l'attenzione della clientela.

Progetto: Adriatic Palace - Jesolo - Italy
Lighting Design: Linealight Group

Prodotti: (n. 11) Barret 9 led 2watt RGB

Contrasting colours set the soaring structure of the original tourist complex off, distinguishing it from the surrounding urban context and attracting the attention of customers.

*Project: Adriatic Palace - Jesolo - Italy
Lighting Design: Linealight Group*

Products used: (n. 11) Barret 9 leds 2 watt RGB

Les jeux de lumière colorée rendent cette structure touristique encore plus élancée, la mettant ainsi en relief par rapport au contexte urbain environnant et attirant l'attention de la clientèle.

*Projet: Adriatic Palace - Jesolo - Italie
Design éclairage: Linealight Group*

Produits: (n. 11) Barret 9 leds 2 watts RGB

Los juegos de colores hacen aún más esbelta la particular estructura turística, para diferenciarla del contexto urbanístico circundante y llamar la atención de los clientes.

*Proyecto: Adriatic Palace - Jesolo - Italia
Lighting Design: LineaLight Group*

Productos: (n. 11) Barret 9 leds 2 watt RGB

Die Farbspiele geben der ungewöhnlichen Hotelstruktur zusätzlichen Schwung und heben sie aus dem umliegenden Stadtbild hervor, um die Aufmerksamkeit der Gäste auf sich zu ziehen.

*Projekt: Adriatic Palace - Jesolo - Italien
Lighting Design: LineaLight Group*

Produkte: (n. 11) Barret 9 LED 2 Watt RGB

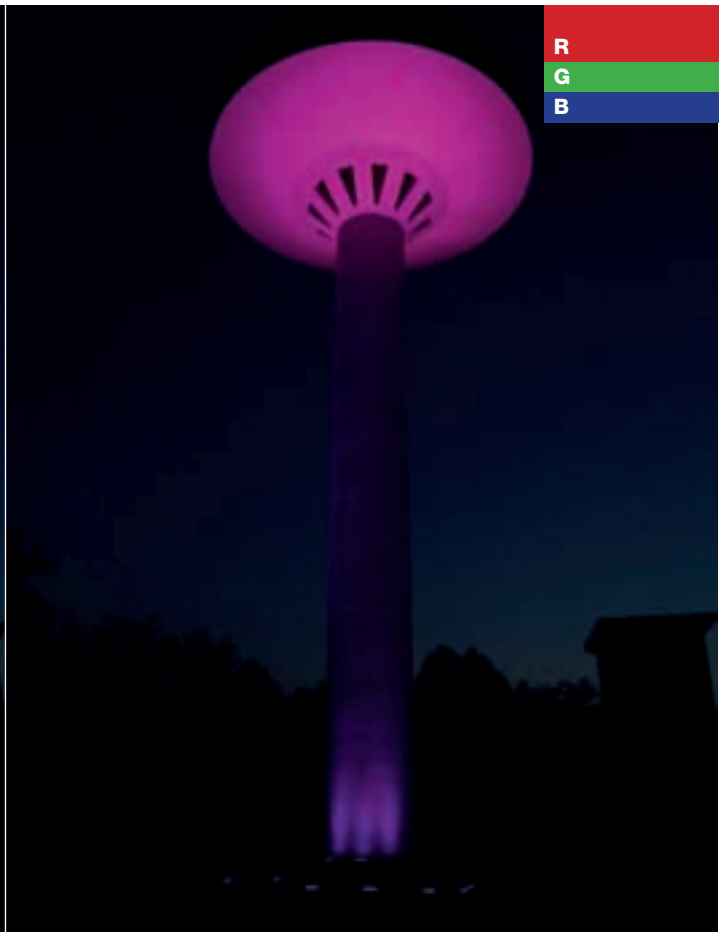

Lo spazio urbano si riveste di luce nuova: anche imponenti strutture architettoniche di servizio riescono così a inserirsi ottimamente nel contesto circostante, trasformandosi nelle ore notturne in elementi attrattivi. Larghezza 15 metri; altezza 40 metri.

Urban spaces are clothed in new light: even imposing architectural structures of public utility fit beautifully into the surrounding context and are transformed into eye-catching attractions during the night. Width 15 metres; height 40 metres.

L'espace urbain se revêt d'une nouvelle lumière même des structures architecturales imposantes de service arrivent ainsi à s'insérer de façon optimale dans le contexte environnant, en se transformant durant les heures nocturnes en éléments d'attraction. Largeur 15 mètres; hauteur 40 mètres.

El espacio urbanístico se viste de una nueva luz: también las imponentes estructuras arquitectónicas auxiliares llegan a integrarse perfectamente en el entorno, convirtiéndose en las horas nocturnas en elementos llamativos. Ancho 15 metros; alto 40 metros.

Der städtische Bereich zeigt sich in neuem Licht: Auch imposante Strukturen des öffentlichen Dienstes lassen sich auf diese Weise optimal in die umliegende Bausubstanz einfügen und werden in den Nachtstunden zu attraktiven Elementen. Breite 15 Meter; Höhe 40 Meter.

Progetto: Acquedotto - Piombino Dese - Italy
Lighting Design: Linealight Group

Project: Waterworks - Piombino Dese - Italy
Lighting Design: Linealight Group

Projet: Aqueduc - Piombino Dese - Italie
Design éclairage: Linealight Group

Proyecto: Acueducto - Piombino Dese - Italia
Lighting Design: LineaLight Group

Projekt: Wasserwerk - Piombino Dese - Italien
Lighting Design: LineaLight Group

Prodotti: Bardir RGB ottica 10°

Products used: Bardir RGB optic 10°

Produits: Bardir RGB, 10°

Productos: Bardir RGB, 10°

Produkte: Bardir RGB, 10°

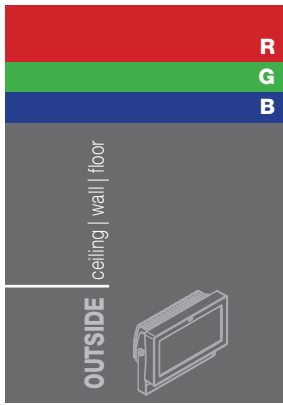

New Farled



New Farled

Proiettore orientabile.
Struttura in alluminio
pressofuso. Diffusore in
vetro temprato. Possibilità
di fissaggio con staffa o
con picchetto.

Adjustable projector,
aluminium Pressure die-
casting case and tempered
glass diffuser. Fixable with
bracket or picket.

Projecteur orientable.
Structure en Aluminium
(Moulage sous pression),
diffuseur en verre trempé.
Possibilité de fixation
avec étrier ou à l'aide d'un
piquet.

Projector orientable.
Estructura en fundición
a presión de aluminio.
Difusor en cristal templado.
Sistema de fijación
con tijas o con piquete.

Ausrichtbare
Leuchte. Struktur aus
Druckgussaluminium.
Lichtdiffusor aus
vorgespanntem Glas.
Befestigungsmöglichkeit mit
Bügeln oder Pflock.

Driver NON compreso

Driver not included
Driver non compris
Driver no incluido
exklusive Driver

vedi cap. Driver
See Driver section
Voir chapitre Drivers
Ver capitolo Driver
siehe Kap. "Driver"

picket optional		2 Watt RGB
	12 LED	
84882	G	87918

picket optional		2 Watt RGB
	21 LED	
84882	G	87924

		2 Watt RGB
	30 LED	
	G	87929

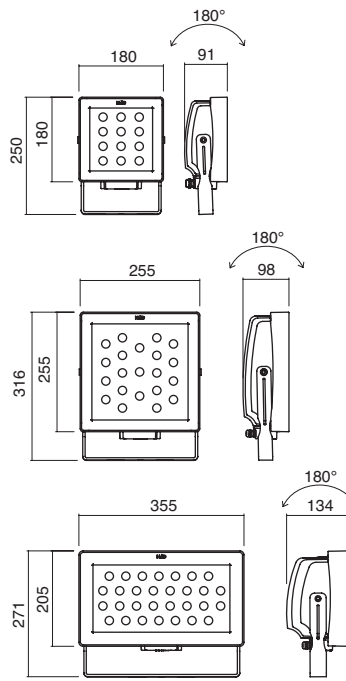

600mA

Opticals	code	Colours
10°	10	Z
30°	30	
50°	50	
70°	70	
120°	12	
Wall Washer 25°	25	



84882
Sistema di fissaggio
con picchetto
Fixing system with picket.
Système de fixation avec
piquet en acier
Sistema de instalacion con piqueta
Erdspließbefestigung

New Farled

Proiettore orientabile.
Struttura in alluminio
pressofuso. Diffusore
in vetro temprato.
Possibilità di fissaggio
con staffa, con base o
con picchetto.

Adjustable projector,
aluminium Pressure die-
casting case and tempered
glass diffuser. Fixable with
bracket, base or picket.

Projecteur orientable.
Structure en Aluminium
(Moulage sous pression),
diffuseur en verre trempé.
Possibilité de fixation
avec étrier, base ou
à l'aide d'un piquet.

Driver compreso

Driver included
Driver compris
Driver incluido
inklusive Driver

Proyector orientable.
Estructura en fundición
a presión de aluminio.
Difusor en cristal templado.
Sistema de fijación
con tijas, con base
o con piquete.

Ausrichtbare
Leuchte. Struktur aus
Druckgussaluminium.
Lichtdiffusor aus
vorgespanntem Glas.
Befestigungsmöglichkeit mit
Bügeln, Basis oder Pflock.

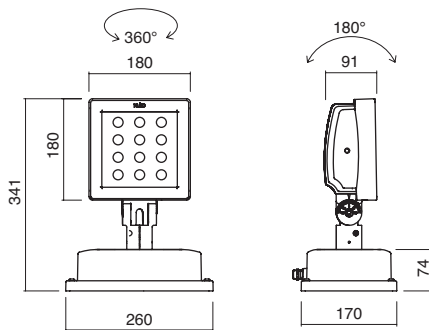
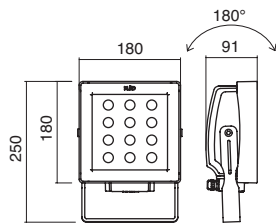

2 Watt RGB

12 LED

optional

87919

G

84882

Con driver e centralina.
Driver and control included. / Driver et central de commande compris.
Driver y controlador incluido. / Inklusive Driver und Steuergerät.

87920

G

84882

84841

84982

Con driver e centralina.
Driver and control included.
Driver et central de commande compris.
Driver y controlador incluido.
Inklusive Driver und Steuergerät.

2 Watt RGB

12 LED

87926

G

Con driver e centralina.
Driver and control included. / Driver et central de commande compris.
Driver y controlador incluido. / Inklusive Driver und Steuergerät.

87925

G

84841

84982

Con driver e centralina.
Driver and control included.
Driver et central de commande compris.
Driver y controlador incluido.
Inklusive Driver und Steuergerät.

87927

G

84982

Con driver e centralina. Controllo IR sul faro
Driver and control included. IR control on the spot light
Driver et central de commande compris. Contrôle IR sur le spot
Driver y controlador incluido. Control IR en el foco
Inklusive Driver und Steuergerät. IR Kontrolle auf der Leuchte



Colours

z

Opticals code

10° 10
30° 30
50° 50
70° 70
120° 12
Wall Washer 25° 25



84882

Sistema di fissaggio
con picchetto
Fixing system with picket.
Système de fixation avec
piquet en acier
Sistema de instalacion con piqueta
Erdspießbefestigung



84841

optional



84982

optional

New Farled



New Farled

Projector orientable.
Estructura en fundición a presión de aluminio.
Difusor en cristal templado.
Sistema de fijación con tijas, con base o con piquete.

Proiettore orientabile.
Struttura in alluminio pressofuso.
Diffusore in vetro temprato.
Possibilità di fissaggio con staffa, con base o con picchetto.

Ausrichtbare Leuchte. Struktur aus Druckgussaluminium.
Lichtdiffusor aus vorgespanntem Glas.
Befestigungsmöglichkeit mit Bügeln, Basis oder Pflock.

Adjustable projector, aluminium Pressure die-casting case and tempered glass diffuser. Fixable with bracket, base or picket.

Projecteur orientable. Structure en Aluminium (Moulage sous pression), diffuseur en verre trempé.
Possibilité de fixation avec étrier, base ou à l'aide d'un piquet.

Driver compreso

Driver included
Driver compris
Driver incluido
inklusive Driver

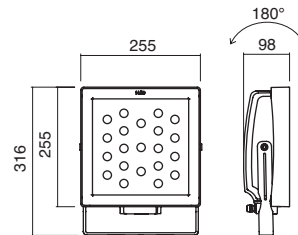

2 Watt RGB

21 LED

optional			
Con driver e centralina. Driver and control included. / Driver et central de commande compris. Driver y controlador incluido. / Inklusive Driver und Steuergerät.	84882	G	87931
Con driver e centralina. Driver and control included. Driver et central de commande compris. Driver y controlador incluido. Inklusive Driver und Steuergerät.	84882 84841 84982	G	87932

2 Watt RGB

21 LED

Con driver e centralina. Driver and control included. / Driver et central de commande compris. Driver y controlador incluido. / Inklusive Driver und Steuergerät.	G	87935	
Con driver e centralina. Driver and control included. Driver et central de commande compris. Driver y controlador incluido. Inklusive Driver und Steuergerät.	84841 84982	G	87934
Con driver e centralina. Controllo IR sul fano Driver and control included. IR control on the spot light Driver et central de commande compris. Contrôle IR sur le spot Driver y controlador incluido. Control IR en el foco Inklusive Driver und Steuergerät. IR Kontrolle auf der Leuchte	84982	G	87936

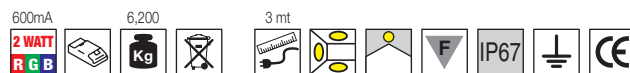
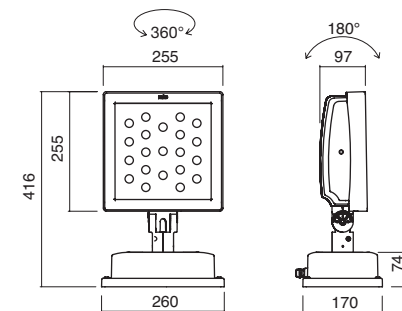

Opticals	code	Colours
10°	10	Z
30°	30	
50°	50	
70°	70	
120°	12	
Wall Washer 25°	25	



84982
optional



84841
optional



84882
Sistema di fissaggio con picchetto
Fixing system with picket.
Système de fixation avec piquet en acier
Sistema de instalacion con piqueta
Erdspließbefestigung

New Farled

Proiettore orientabile.
Struttura in alluminio
pressofuso. Diffusore
in vetro temprato.
Possibilità di fissaggio
con staffa o con base.

Adjustable projector,
aluminium Pressure die-
casting case and tempered
glass diffuser. Fixable with
bracket or base.

Projecteur orientable.
Structure en Aluminium
(Moulage sous pression),
diffuseur en verre trempé.
Possibilité de fixation avec
étrier ou base.

Proyector orientable.
Estructura en fundición
a presión de aluminio.
Difusor en cristal templado.
Sistema de fijación con tijas
o con base.

Ausrichtbare
Leuchte. Struktur aus
Druckgussaluminium.
Lichtdiffusor aus
vorgespanntem Glas.
Befestigungsmöglichkeit mit
Bügeln oder mit Basis.

Driver compreso

Driver included
Driver compris
Driver incluido
inklusive Driver

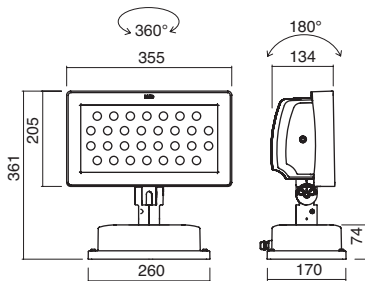
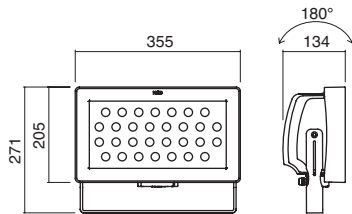

2 Watt RGB

30 LED

optional

87938



Con driver e centralina.
Driver and control included. / Driver et central de commande compris.
Driver y controlador incluido. / Inklusive Driver und Steuergerät.

87939



84841
84982

Con driver e centralina.
Driver and control included.
Driver et central de commande compris.
Driver y controlador incluido.
Inklusive Driver und Steuergerät.

2 Watt RGB

30 LED

87941



Con driver e centralina.
Driver and control included. / Driver et central de commande compris.
Driver y controlador incluido. / Inklusive Driver und Steuergerät.

87940



84841
84982

Con driver e centralina.
Driver and control included.
Driver et central de commande compris.
Driver y controlador incluido.
Inklusive Driver und Steuergerät.

87942



84982

Con driver e centralina. Controllo IR sul faro
Driver and control included. IR control on the spot light
Driver et central de commande compris. Contrôle IR sur le spot
Driver y controlador incluido. Control IR en el foco
Inklusive Driver und Steuergerät. IR Kontrolle auf der Leuchte



Colours



Opticals code

10°	10
30°	30
50°	50
70°	70
120°	12
Wall Washer 25°	25



84841
optional



84982
optional