

Track system elettrificato monofase a bassissima tensione 24V, in alluminio estruso cromato. Di grande versatilità per innumerevoli soluzioni illuminotecniche e d'arredo grazie ad un'ampia gamma di spot, sospensioni e flessibili, che possono essere posizionate a piacimento.

Assume le forme più diverse desiderate dall'utilizzatore.

Disponibilità di sorgenti a 1 o 2 watt, con varie ottiche e colori.

Il sistema comprende una serie di accessori che consentono il collegamento meccanico ed elettrico a più binari. Grazie a tali accessori possiamo avere tre versioni:

- 1) versione sospesa tramite tondino distanziale
- 2) a filo parete ideali per musei, negozi e spazi abitativi
- 3) versione specifica per vetrine espositive

Single-phase powered track with a very low voltage: 24V, in extruded chromed aluminium. Very versatile and offering numerous technical-lighting and furnishing possibilities thanks to a wide range of spotlights, ceiling-hung and flexible lightings that can be positioned as wished. It can take on the shapes desired by the user. The sources can be 1 or 2 watt with various optical lenses and colours. The system includes a set of accessories that allow the mechanical and electric connections to various tracks. Thanks to these accessories, three versions are possible:

- 1) *Version suspended by means of spacer rod*
- 2) *Version flush with the wall ideal for museums, halls, shops and rooms in the house.*
- 3) *Special version for display cases*

Rail électrifié monophasé à très basse tension 24V, en aluminium extrudé chromé. Il se caractérise par sa grande versatilité permettant d'innombrables solutions d'illumination et de décoration grâce à une large gamme de spots, de suspensions et de flexibles pouvant être installés selon les exigences. Il est en mesure de prendre les formes les plus variées selon les besoins de l'utilisateur. Disponibilité de sources de lumière à 1 ou 2 watts, dotées de différents types de lentilles optiques et disponibles en plusieurs couleurs. Ce système comprend une série d'accessoires permettant le raccordement mécanique et électrique à plusieurs rails. Grâce à ces accessoires nous avons donc trois versions à disposition:

- 1) *Version en suspension avec baguette d'écartement*
- 2) *Version encastrée en raz de mur, idéal pour les musées, halls, magasins, habitations*
- 3) *Version spécifique pour vitrines d'exposition*

Carril electrificado monofásico de muy baja tensión 24V, en aluminio extrusionado cromado. De gran versatilidad en un sinfín de soluciones para el alumbrado y la decoración interior gracias a la extensa gama de spots, luces suspendidas y flexos, que se pueden colocar a elección. Va asumiendo las formas más distintas que el usuario prefiera. Disponibilidad de fuentes de 1 ó 2 watt, con varias ópticas y colores. El sistema incluye una gama de accesorios que permiten la conexión mecánica y eléctrica entre más carriles. Gracias a estos accesorios están disponibles tres versiones:

- 1) *Versión colgante con hierro redonda distanciadador*
- 2) *Versión a ras de la pared ideal para museos, salones, tiendas, espacios habitativos*
- 3) *Versión específica para vitrinas expositivas*

Einphasiges elektrifiziertes Schienensystem mit Niederspannung 12V aus verchromtem Aluminium-Druckguss. Dieses vielseitige System bietet durch das große Angebot von beliebig einsetzbaren Leuchtstrahlern, Hängeleuchten und schwenkbaren Strahlern unzählige beleuchtungs- und einrichtungstechnische Lösungen. Es nimmt jede vom Benutzer gewünschte Form an und steht mit Lichtquellen mit 1 oder 2 Watt und mit verschiedenen Optiken und Farben zur Verfügung. Das System umfasst eine Reihe von Zubehörteilen, die den mechanischen und elektrischen Anschluss an mehrere Schienen ermöglichen. Dank diesem Zubehör sind drei Versionen lieferbar:

- 1) *Hängende Ausführung mit Distanzrundenisen*
- 2) *Wandbündige Ausführung, ideal für Museen, Halls, Geschäfte, Wohnungen.*
- 3) *Spezifische Ausführung für Ausstellungsvitrinen*



Esposizione di orologi di valore: bianco caldo per materiale colorato (es pietre ed oro giallo-rosso), mentre luce fredda per metalli, acciai e oro bianco. La luce emessa non scalda gli oggetti esposti. Prodotti: Sina 3led 2watt bianco caldo, Sina 2led 2watt bianco caldo, Lisken 3led 2 watt bainco freddo. / Display of valuable watches: warm white for coloured materials (e.g precious stones and yellow-red gold), and cold light for metals, steel and white gold. The light emitted does not heat the displayed objects. Products used: Sina 3 leds 2 watt warm white, Sina 2 leds 2 watt warm white, Lisken 3 leds 2 watt cold white. / Exposition de montres de valeur: une lumière blanc chaud pour les matériaux colorés (p. ex. pierres précieuses et or jaune et rouge), au contraire, une lumière froide pour les métaux, l'acier et l'or blanc. La lumière émise ne réchauffe pas les objets exposés. Produits: Sina 3 leds 2 watts blanc chaud, Sina 2 leds 2 watts blanc chaud, Lisken 3 leds 2 watts blanc froid. / Exposición de relojes preciados: blanco cálido para el material coloreado (por ej. piedras y oro amarillo-rojo) y luz fría para metales, aceros y oro blanco. La luz emitida no calienta los objetos expuestos. Productos: Sina 3 leds 2 watt blanco cálido, Sina 2 leds 2 watt blanco cálido Lisken 3 leds 2 watt blanco frío. / Ausstellung wertvoller Uhren: Warmweiß für farbige Materialien (z.B. Edelsteine und Gelb- oder Rotgold), Kaltlicht bei Metallen, Stahl und Weißgold. Das abgestrahlte Licht führt zu keiner Erwärmung der ausgestellten Objekte. Produkte: Sina 3 led 2 Watt Warmweiß, Sina 2 led 2 Watt Warmweiß - Lisken 3 led 2 Watt Kaltweiß.

Per applicazioni simili si consiglia l'uso di articoli alimentati ad 1 Watt

For similar applications you are advised to use items powered by 1 Watt. / Pour des applications semblables, il est recommandé d'utiliser des articles avec alimentation à 1 Watt. / Para aplicaciones similares se recomienda la utilización de artículos alimentados con 1 Watt. / Für ähnliche Anwendungen empfehlen wir die Anwendung von mit 1 Watt gespeisten Artikeln.



Luce d'accento su opere di valore, enfatizzandone le peculiarità e rispettandone sempre la conservazione. La modularità degli articoli a led permette di coprire zone di varie dimensioni.

Focused light on works of art sets off special features while always respecting conservation. The modularity of the led lights allow you to cover areas of various sizes.

Un éclairage d'accent sur les œuvres de valeur pour enphatiser leur authenticité tout en respectant leur conservation. La modularité des articles à leds permet de couvrir des surfaces de différentes dimensions.

Luz puntual sobre obras valiosas, enfatizando su peculiaridad y respetando siempre su conservación. La modularidad de los artículos de leds permite alcanzar zonas de vario tamaño.

Akzentlicht auf kostbaren Kunstwerken betont die Besonderheiten ohne dabei die Konservierung zu beeinträchtigen. Die Modularität der LED Artikel ermöglicht die Beleuchtung von Räumen unterschiedlicher Dimensionen.

Progetto: Museo Civico - Pordenone - IT
Lighting Design: Linealight Group

Project: Municipal Museum - Pordenone - ITALY
Lighting Design: Linealight Group

Projet: Musée Civique - Pordenone - Italie
Design éclairage: Linealight Group

Proyeta: Museo Municipal - Pordenone - Italia
Lighting design: Linealight Group

Projekt: Stadtmuseum - Pordenone - Italien
Lighting Design: Linealight Group

Prodotti: Linnar 6led 2watt bianco caldo, Sina 2led 2watt bianco caldo, Frida 3led 2watt Sina 2led 2watt

Products used: Linnar 6led 2 watt warm white, Sina 2led 2 watt warm white, Frida 3led 2 watt, Sina 2led 2 watt

Produits: Linnar 6 leds 2 watts blanc chaud, Sina 2 leds 2 watts blanc chaud, Frida 3 leds 2 watts, Sina 2 leds 2 watts

Productos: Linnar 6 leds 2 watt blanco cálido, Sina 2 leds 2 watt blanco cálido, Frida 3 leds 2 watt, Sina 2 leds 2 watt

Produkte: Linnar 6 led 2 Watt Warmweiß, Sina 2 led 2 Watt Warmweiß, Frida 3 led 2 Watt, Sina 2 led 2 Watt



Maja



Maja

Foco orientabile con corpo in alluminio y latón.

Systemleuchte mit dreh- und schwenkbarem Gelenk, Gehäuse aus Aluminium und Messing.

Faretto a snodo orientabile. Corpo in alluminio e ottone.

Aluminium and brass spotlight with adjustable joint.

Spot avec bras orientable. Corps en Aluminium et laiton.

2 Watt 1 Watt

C	87285	87282	1 LED
C	87286	87283	1+1 LED
C	87287	87284	1+1+1 LED

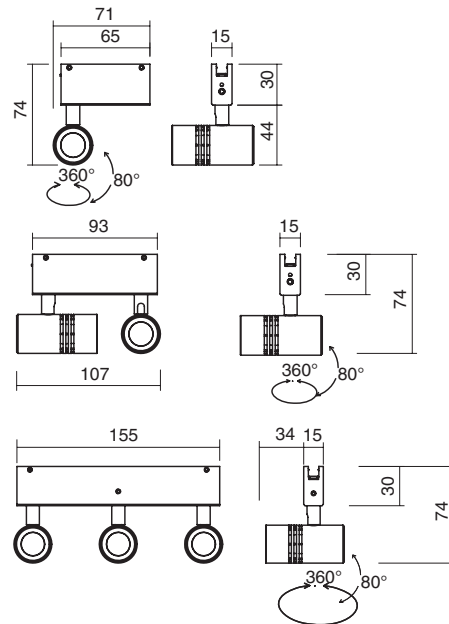

Driver compreso

Driver included
Driver compris
Driver incluido
inklusive Driver

600 mA 350mA
24 VDC 24VDC

0,250
0,340
0,420

2 WATT POWER **1 WATT POWER**

Opticals	code	Colours
Diffused	00	C
10°	10	W
30°	30	N
50°	50	B
70°	70	Y
120°	12	R
		G

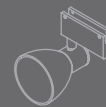

Dicro

Faretto orientabile a snodo. Corpo in alluminio e ottone. Diffusore in vetro dicroizzato.

Aluminium and brass spotlight with adjustable joint. Dichroic glass diffuser.

Spot avec bras orientable. Corps en Aluminium et laiton. Diffuseur en verre Dichroïque.

Foco orientable con articulación. Cuerpo en aluminio y latón. Difusor en cristal dicroico.

Systemleuchte mit dreh- und schwenkbarem Gelenk und dichroitischem Reflektor. Gehäuse aus Aluminium und Messing.



Driver compreso

Driver included
Driver compris
Driver incluido
inklusive Driver

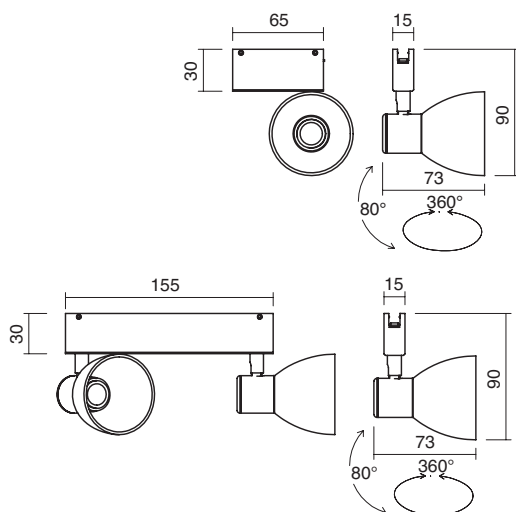

1 Watt 2 Watt

	1 Watt	2 Watt	
1 LED	87309	87310	C
1+1 LED	87311	87312	C



Colours	Opticals	code
C	50°	50
W		
N		
B		
Y		
R		
G		



Frida



Frida

Faretto a snodo orientabile.
Corpo in alluminio.

Aluminium spotlight with adjustable joint.
Spot avec bras orientable.
Corps en Aluminium.

Foco orientable con cuerpo en aluminio.
Systemleuchte mit dreh- und schwenkbarem Gelenk. Gehäuse aus Aluminium.

2 Watt **1 Watt**

C	87306	87305	3 LED
C	87314	87313	6 LED

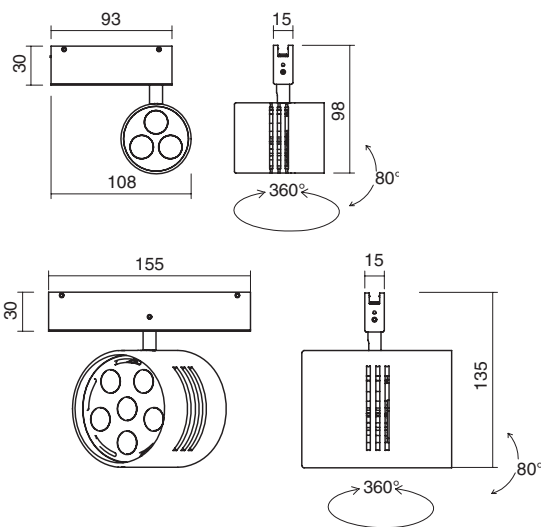

Driver compreso
Driver included
Driver compris
Driver incluido
inklusive Driver

600 mA 350mA 0,260
24 VDC 24VDC 0,350

Opticals	code	Colours
Diffused	00	C
10°	10	W
30°	30	N
50°	50	B
70°	70	Y
120°	12	R
		G



Sina

Faretto rettangolare a snodo orientabile.
Corpo in alluminio.

Rectangular spotlight in aluminium with adjustable joint.

Spot rectangulaire avec bras orientable. Corps en Aluminium.

Foco rectangular con articulación.
Cuerpo en aluminio.

Systemleuchte, Gehäuse rechteckig aus Aluminium, mit schwenkbarem Gelenk.



Driver compreso

Driver included
Driver compris
Driver incluido
inklusive Driver

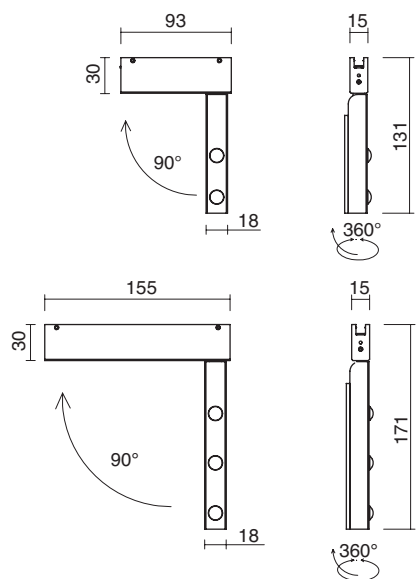

1 Watt

2 LED	87298	C
3 LED	87300	C



Colours	Opticals	code
C	50°	50
W	70°	70
N		
B		
Y		
R		
G		

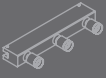

Lisken



*Foco orientable
con articulación.
Cuerpo en aluminio.*

*Systemleuchte,
Gehäuse aus Aluminium,
Leuchtenköpfe
dreh- und schwenkbar.*

Lisken

**Faretti a snodo
orientabili.
Corpo in alluminio**

*Adjustable joint spotlight.
Aluminium case.*

*Spot avec bras orientable.
Corps en Aluminium.*

2 Watt 1 Watt

C

87302

87301

1+1+1 LED

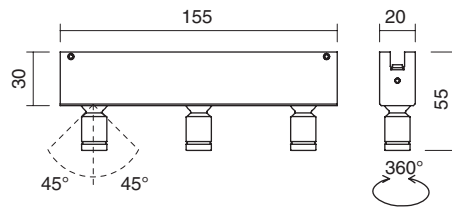

Driver compreso

*Driver included
Driver compris
Driver compris
inklusive Driver*

500 mA 350mA
24 VDC 24VDC

2 WATT POWER **1 WATT POWER** 0,270 850°

Opticals	code	Colours
30°	30	C
50°	50	W
70°	70	N
		B
		Y
		R
		G

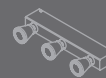

INSIDE track system

Valborg

- living inside

Valborg

Faretti a snodo orientabili.
Corpo in alluminio.

Adjustable joint spotlight.
Aluminium case.

Spot avec bras orientable.
Corps en Aluminium.

Foco orientable
con cuerpo en aluminio.

Systemleuchte,
Gehäuse aus Aluminium,
Leuchtenköpfe
dreh- und schwenkbar.



Driver compreso

Driver included
Driver compris
Driver compris
inklusive Driver

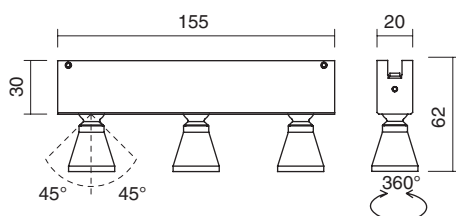

1 Watt

2 Watt

1+1+1 LED

87303

87304

C

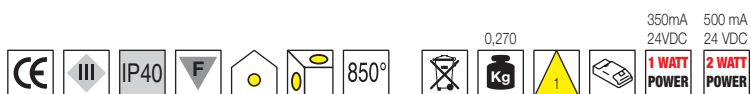

Colours	Opticals	code
C	10°	10
W	30°	30
N		
B		
Y		
R		
G		



Marit



Foco doble con cuerpo en aluminio.

Ausrichtbare Doppelleuchte. Gehäuse aus Aluminium.

Marit

Doppio faretto orientabile. Corpo in alluminio.

Double adjustable spotlight. Aluminium case.

Spot avec bras orientable. Corps en Aluminium.

2 Watt 1 Watt

C	87291	87288	1+1 LED
---	-------	-------	---------

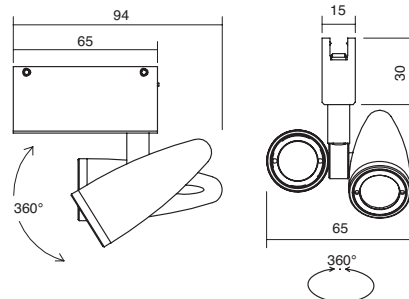

Driver compreso

Driver included
Driver compris
Driver incluido
inklusive Driver

500 mA 350 mA
24 VDC 24VDC

2 WATT POWER 1 WATT POWER

0,250

850°

Opticals	code	Colours
10°	10	C
30°	30	W
50°	50	N
		B
		Y
		R
		G



illuminazione omogenea sull'intera superficie del quadro facendone risaltare gli originali colori e rispettandone la conservazione grazie alle basse emissioni di calore ed assenza di raggi UV.

Progetto: Museo Civico - Pordenone - Italy
Lighting Design: Linealight Group

Prodotti: Linnar 6led 2watt bianco caldo Sina 2led 2watt bianco caldo

The evenly distributed light over the whole surface of the picture sets off the original colours and respects conservation thanks to low heat emissions and absence of UV rays.

*Project: Municipal museum - Pordenone - Italy
Lighting Design: Linealight Group*

Products used: Linnar 6 leds 2 watt warm white Sina 2 leds 2 watt warm white

L'éclairage, étant homogène sur toute la surface du tableau, fait ressortir les couleurs d'origine tout en respectant leur conservation grâce aux faibles émissions de chaleur et à l'absence de rayons UV.

*Projet: Musée Civique - Pordenone - Italie
Design éclairage: Linealight Group*

Produits: Linnar 6 leds 2 watts blanc chaud Sina 2 leds 2 watts blanc chaud

Iluminación homogénea de la entera superficie del lienzo resaltando los colores originales y respetando su conservación gracias a las bajas emisiones de calor y a la ausencia de radiación UV.

*Proyecto: Museo Municipal - Pordenone - Italia
Lighting Design: Linealight Group*

Productos: Linnar 6 leds 2 watt blanco cálido Sina 2 leds 2 watt blanco cálido

Die gleichmäßige Beleuchtung der gesamten Oberfläche des Gemäldes hebt die Originalfarben hervor. Da keine schädlichen UV Strahlen entstehen werden Gemälde und Kunstwerke nicht geschädigt.

*Projekt: Stadtmuseum - Pordenone - Italien
Lighting Design: Linealight Group*

Produkte: Linnar 6 LED 2Watt Warmweiß Sina 2 LED 2Watt Warmweiß

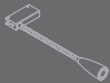

Stina



Foco flexible.
Cuerpo en aluminio.

Flexible Leuchte.
Gehäuse aus Aluminium.

Stina

Faretto flessibile.
Corpo in alluminio.

Flexible spotlight.
Aluminium case.

Spot flexible.
Corps en Aluminium.

2 Watt 1 Watt

C 87292 87289 1 LED

C 87293 87290 1+1 LED

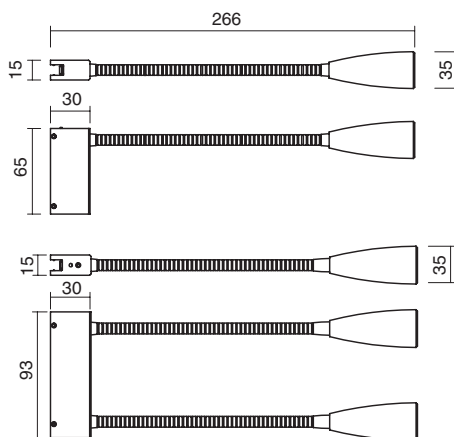

Driver compreso

Driver included
Driver compris
Driver incluido
inklusive Driver

600 mA 350mA 0,170
24 VDC 24VDC 0,320

2 WATT POWER 1 WATT POWER

850°

Opticals	code	Colours
10°	10	C
30°	30	W
50°	50	N
		B
		Y
		R
		G

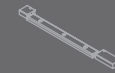

Linnar

Profilo rettangolare orientabile.
Corpo in alluminio.

Adjustable rectangular section. Aluminium case.

Réglette rectangulaire orientable.
Corps en Aluminium.

Perfil rectangular orientable.
Cuerpo en aluminio.

Ausrichtbares rechteckiges Profil. Gehäuse aus Aluminium.



Driver compreso

Driver included
Driver compris
Driver incluido
inklusive Driver

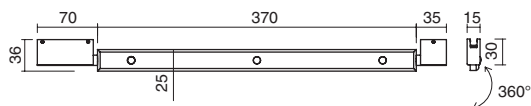

1 Watt

2 Watt

3 LED

87294

87295

C

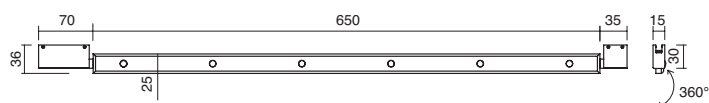

6 LED

87296

87297

C

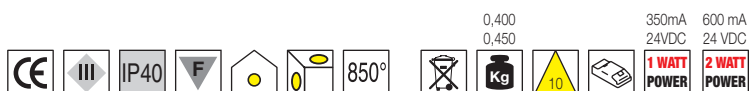

Colours	Opticals	code
C	30°	30
W	50°	50
N	70°	70
B	120°	12
Y		
R		
G		

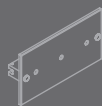

Marna



Foco con luz difusa y con cristal plano serigrafado. Cuerpo en aluminio.

Systemleuchte, Gehäuse aus Aluminium, Lichtaustritt diffus mittels matterter Scheibe.

Marna

Faretto a luce diffusa con vetro piano serigrafato. Corpo in alluminio.

Spotlight with diffused light with silk screened glass. Aluminium case.

Spot à éclairage diffusé avec verre plat sérigraphié. Corps en Aluminium.

2 Watt

C

87308

2 LED

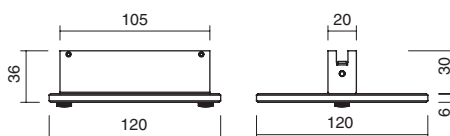

Driver compreso

Driver included
Driver compris
Driver incluido
inklusive Driver

C

87307

3 LED

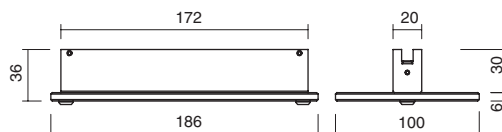

500mA
24 VDC



0,730
0,850



850°



Opticals	code	Colours
Diffused	00	<ul style="list-style-type: none"> ● C ● W ● N ● B ● Y ● R ● G



INSIDE track system

Agda

e - living inside

Agda

Faretto a sospensione.
Corpo in alluminio.

Overhanging spotlight.
Aluminium case.

Spot en suspension.
Corps en Aluminium.

Colgante con cuerpo
hecho en aluminio.

System - Pendelleuchte,
Gehäuse aus Aluminium.



Driver compreso

Driver included
Driver compris
Driver incluido
inklusive Driver

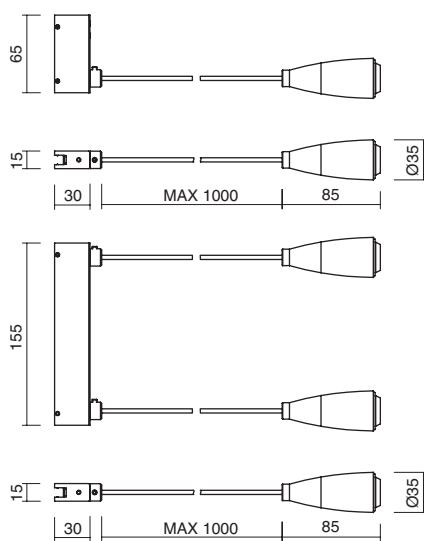

1 Watt 2 Watt

	1 Watt	2 Watt	
1 LED	87315	87316	C
1+1 LED	87317	87318	C

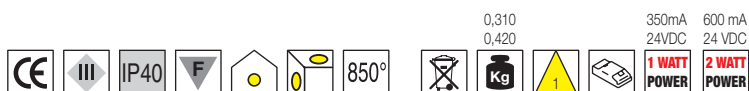

Colours	Opticals	code
C	10°	10
W	30°	30
N	50°	50
B		
Y		
R		
G		



Song



Colgante con
cristal dicroico.
Cuerpo en aluminio
y latón.

System - Pendelleuchte,
Gehäuse aus Aluminium
und Messing, mit
dichroitischem
Filter

Song

Faretto a sospensione
con vetro dicroicizzato.
Corpo in alluminio
e ottone.

Overhanging spotlight with
dichroic glass.
Aluminium and brass case.

Spot en suspension avec
verre dichroïque.
Corps en Aluminium
et laiton.

2 Watt 1 Watt

C 87320 87319 1 LED

C 87322 87321 1+1 LED

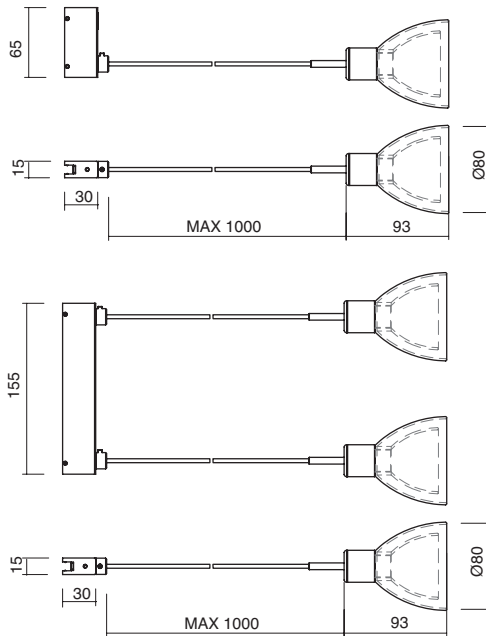

Driver compreso

Driver included
Driver compris
Driver incluido
inklusive Driver

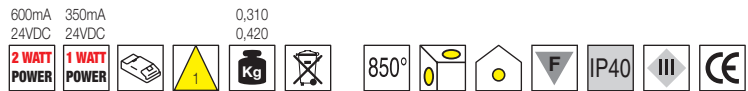

Opticals	code	Colours
50°	50	<ul style="list-style-type: none"> ● C ● W ● N ● B ● Y ● R ● G



Le ridotte emissioni di calore permettono di esporre prodotti alimentari come il cioccolato, senza alterarne le proprietà organolettiche.

Progetto: Ricostruzione vetrine espositive
Lighting Design: LineaLight Group

Prodotti: Maya 2led 1watt luce calda, Sina 3led 1watt luce calda, Sina 2led 1watt luce calda

The reduced heat emissions make it possible to exhibit foodstuffs such as chocolate without altering their organoleptic properties.

Project: Makeover of showcases
Lighting Design: LineaLight Group

Products used: Maya 2 leds 1 watt warm light, Sina 3 leds 1 watt warm light, Sina 2 leds 1 watt warm light

Les faibles émissions de chaleur permettent d'exposer des produits alimentaires comme le chocolat sans en altérer les propriétés organoleptiques.

Projet: Reconstruction de vitrines présentoirs.
Design éclairage: LineaLight Group

Produits: Maya 2 leds 1 watts lumière chaude, Sina 3 leds 1 watts lumière chaude, Sina 2 leds 1 watts lumière chaude

Las reducidas emisiones de calor permiten exponer productos alimenticios como el chocolate, sin alterar sus propiedades organolépticas.

Proyecto: Restauración vitrinas de exposición
Lighting Design: LineaLight Group

Productos: Maya 2 leds 1 watt luz cálida, Sina 3 leds 1 watt luz cálida, Sina 2 leds 1 watt luz cálida

Durch die geringe Wärmeabgabe können Lebensmittel wie zum Beispiel Schokolade ausgestellt werden, ohne ihre organoleptischen Merkmale zu beeinträchtigen.

Projekt: Aufbau von Ausstellungsvitrinen
Lighting Design: LineaLight Group

Produkte: Maya 2 led 1 Watt Warmlicht, Sina 3 led 1 Watt Warmlicht, Sina 2 led 1 Watt Warmlicht

Per applicazioni simili si consiglia l'uso di articoli alimentati ad 1 Watt / For similar applications you are advised to use items powered by 1 Watt. / Pour des applications semblables, il est recommandé d'utiliser des articles avec alimentation à 1 Watt. / Para aplicaciones similares se recomienda la utilización de artículos alimentados con 1 Watt. / Für ähnliche Anwendungen empfehlen wir die Anwendung von mit 1 Watt gespeisten Artikeln.

Schema applicativo per binario sospeso e relativi accessori

- La lunghezza massima realizzabile con spot uniformemente distribuiti è di 15 metri.
- La distanza massima tra un supporto e l'altro è di 1 metro
- Il dimensionamento dell'impianto è: $Watt \text{ del driver} = 4V \text{ (led)} \times mA \text{ (Power)} \times n. \text{ leds} \times 1.1 \text{ (coefficiente)}$

Applicative schematic for track suspended and relative accessories

- The maximum length that can be achieved with uniformly distributed projectors is 15 metres
- The maximum distance between one support and the next is 1 metre
- System scaling is: $driver Watt = 4V \text{ (led)} \times mA \text{ (Power)} \times n. \text{ leds} \times 1.1 \text{ (coefficient)}$

Schéma d'application pour rail suspendu et accessoires correspondants

- La longueur maximale réalisable avec des spots distribués de façon uniforme est de 15 m.
- La distance maximale entre un support et l'autre est de 1 m.
- Dimensionnement de l'installation: $driver Watt = 4V \text{ (led)} \times mA \text{ (Power)} \times n. \text{ leds} \times 1.1 \text{ (coefficient)}$

Esquema de aplicación para carril colgante y accesorios relativos

- La longitud máxima realizable con focos distribuidos uniformemente es de 15 metros.
- La distancia máxima entre un soporte y el otro es de 1 metro
- El dimensionamiento de la instalación es: $driver Watt = 4V \text{ (led)} \times mA \text{ (Power)} \times n. \text{ leds} \times 1.1 \text{ (coefficient)}$

Anbringungsschema für hängende Schiene und diesbezügliches Zubehör

- Die mit einem Spot ausführbare gleichmäßig verteilte Höchstlänge beträgt 15 Meter.
- Die Höchstlänge zwischen einer Halterung und der anderen beträgt 1 Meter
- Die Abmessungen der Anlage beträgt: $driver Watt = 4V \text{ (led)} \times mA \text{ (Power)} \times n. \text{ leds} \times 1.1 \text{ (coefficient)}$



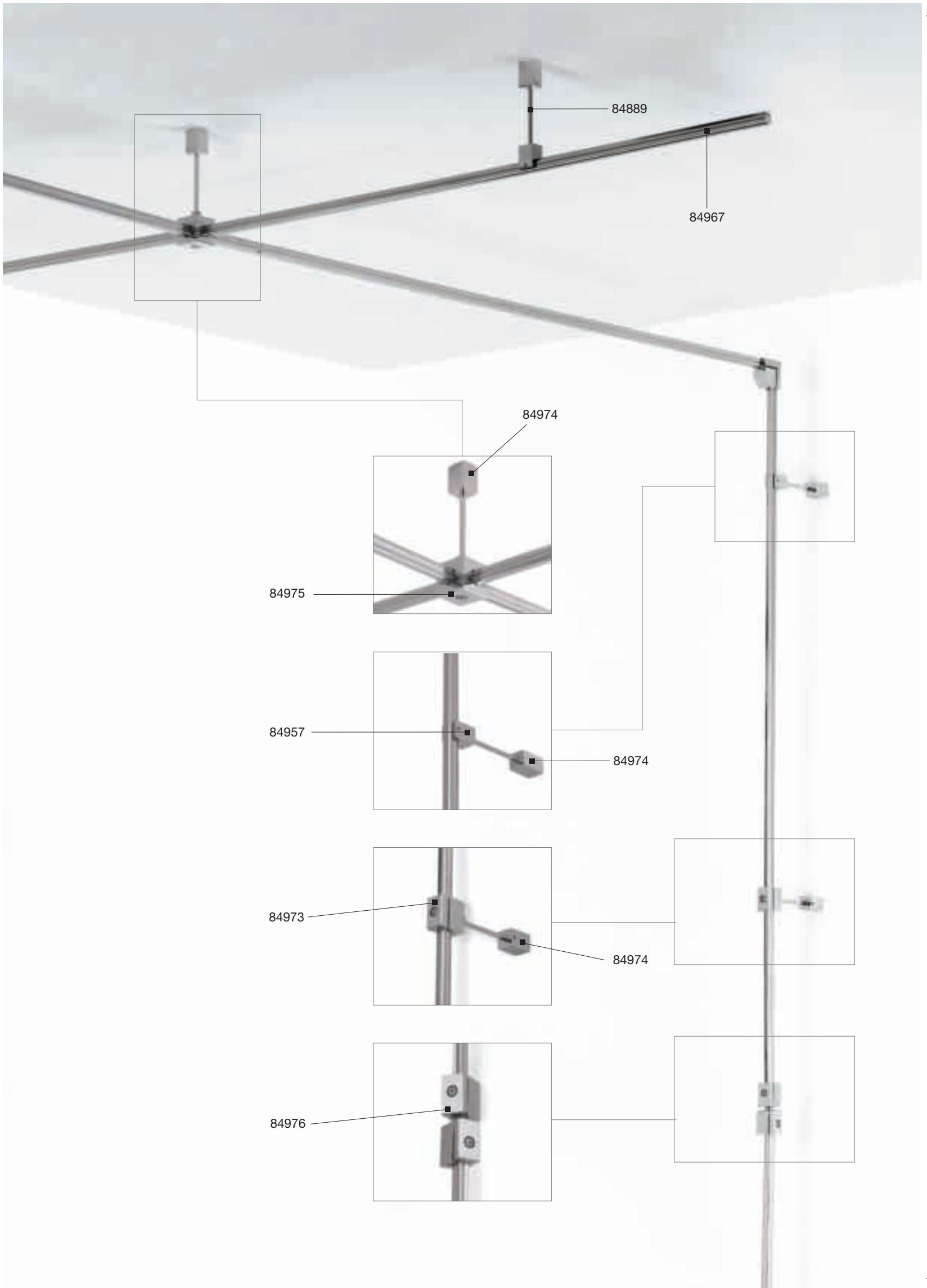

Accessori

C 84973

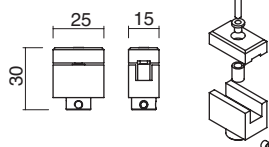

Giunzione lineare.
 Linear coupling / Jonction linéaire /
 Junta lineal / Lineare Verbindung

C 84971

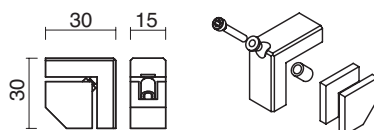

Giunzione con curva 90°.
 Junction with 90° curve / Jonction
 avec angle à 90° / Enlace con curva
 90° / Verbindung mit 90°-Biegung.

C 84970

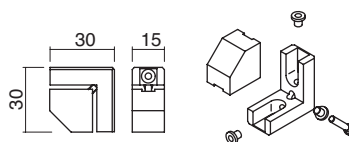

Giunzione con curva 90°.
 Junction with 90° curve / Jonction
 avec angle à 90° / Enlace con curva
 90° / Verbindung mit 90°-Biegung.

C 84972

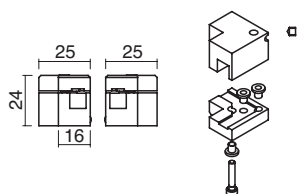

Giunzione con curva 90°.
 Junction with 90° curve / Jonction
 avec angle à 90° / Enlace con curva
 90° / Verbindung mit 90°-Biegung.

C 84975

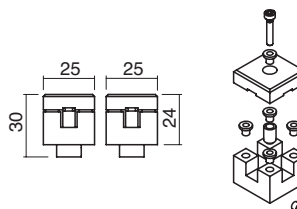

Giunzione a 4 vie
 Four-way coupling / Jonction à quatre
 voies / Junta de cuatro vías /
 4-Wege-Verbindung

C 84966

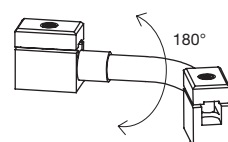

Curva flessibile 180°
 180° flexible bend / Coude flexible 180° /
 Curva flexible 180° / Flexible Kurve 180°

Accessori - Snodi, supporti e asta track system

Accessories - Joint, supports and track system bar

Accessoires - Bras articulé, supports et carril track system

Accesorios - Articulación, soportes y asta track system

Zubehör - Gelenke, halterungen und Track System-Teilen

Snodo rotazione 360°
360° swivel joint
Articulation rotation 360°
Articulación con rotación de 360°
Drehgelenk 360°

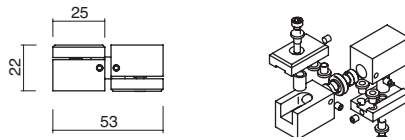

84976 **C**

Supporto per ancoraggio binario
Track anchorage support
Support pour fixation rail
Soporte para la fijación del carril
Halterung für Schienenverankerung

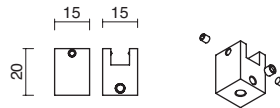

84957 **C**

Supporto per fissaggio a muro
Support for wall fixing
Support pour fixation au mur
Soporte para la fijación en la pared
Halterung für Wandbefestigung

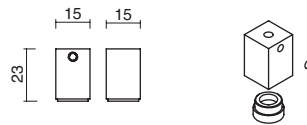

84974 **C**

Asta distanziale *
Spacer bar
Tige d'écartement
Barra distanciadora
Distanzstange

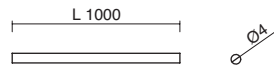

84889 **C**

Binario *
Track
Rail
Carril
Schiene

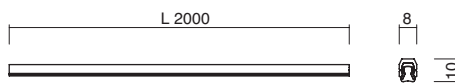

84967 **C**

*** Da sezionare in base alla necessità**
To be selected based on need
Sectionner en fonction des exigences
De seccionarse según las exigencias
Zur Unterteilung je nach Bedarf

● NEGATIVO / NEGATIVE
● ISOLANTE / INSULATOR
● POSITIVO / POSITIVE



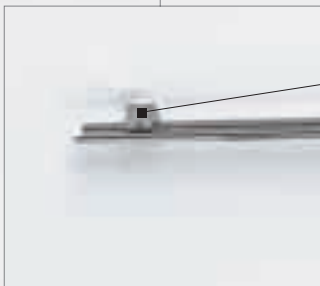

84960



84963



84965



84962



84962



84961

Schema applicativo per binario a filo e relativi accessori

- La lunghezza massima realizzabile con spot uniformemente distribuiti è di 15 metri.
- La distanza massima tra un supporto e l'altro è di 1 metro
- Il dimensionamento dell'impianto è: $\text{Watt del driver} = 4V (\text{led}) \times \text{mA} (\text{Power}) \times \text{n. leds} \times I.I (\text{coefficiente})$

Applicative schematic for flush track and relative accessories

- The maximum length that can be achieved with uniformly distributed projectors is 15 metres
- The maximum distance between one support and the next is 1 metre
- System scaling is: $\text{driver Watt} = 4V (\text{led}) \times \text{mA} (\text{Power}) \times \text{n. leds} \times I.I (\text{coefficient})$

Schéma d'application pour rail à raz et accessoires correspondants

- La longueur maximale réalisable avec des spots distribués de façon uniforme est de 15 m.
- La distance maximale entre un support et l'autre est de 1 m.
- Dimensionnement de l'installation: $\text{driver Watt} = 4V (\text{led}) \times \text{mA} (\text{Power}) \times \text{n. leds} \times I.I (\text{coefficient})$

Esquema de aplicación para carril a ras y accesorios relativos

- La longitud máxima realizable con focos distribuidos uniformemente es de 15 metros.
- La distancia máxima entre un soporte y el otro es de 1 metro
- El dimensionamiento de la instalación es: $\text{driver Watt} = 4V (\text{led}) \times \text{mA} (\text{Power}) \times \text{n. leds} \times I.I (\text{coefficient})$

Anbringungsschema für bündige Schiene und diesbezügliche Zubehörteile

- Die mit einem Spot ausführbare gleichmäßig verteilte Höchstlänge beträgt 15 Meter.
- Die Höchstlänge zwischen einer Halterung und der anderen beträgt 1 Meter
- Die Abmessungen der Anlage beträgt: $\text{driver Watt} = 4V (\text{led}) \times \text{mA} (\text{Power}) \times \text{n. leds} \times I.I (\text{coefficient})$

Accessori per binario a filo superficie
Flush track accessories
Accessoires pour rail à ras
Accesorios para riel a ras
Zubehör für bündige Schiene

Supporto centrale
Central support / Support central /
Soporte central / Mittlere Halterung

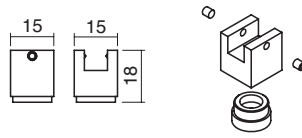

84960 **C**

Giunzione lineare.
Linear coupling / Jonction linéaire /
Junta lineal / Lineare Verbindung

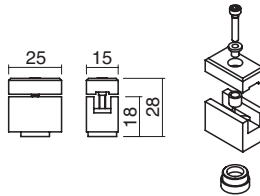

84964 **C**

Giunzione a 90°.
90° coupling / Jonction à 90° /
Junta a 90° / 90°-Verbindung

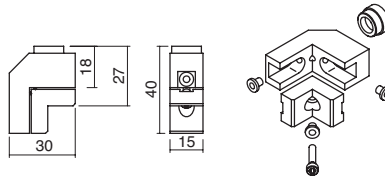

84962 **C**

Giunzione a 90°.
90° coupling / Jonction à 90° /
Junta a 90° / 90°-Verbindung

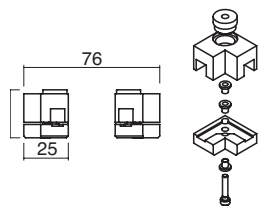

84961 **C**

Giunzione a 4 vie
Four-way coupling / Jonction à quatre
voies / Junta de cuatro vías /
4-Wege-Verbindung

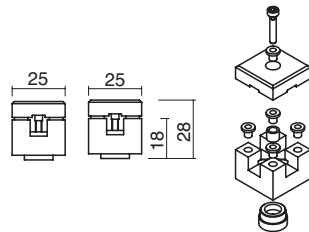

84963 **C**

Curva flessibile 180°
180° flexible bend / Coude flexible
180° / Curva flexible 180° / Flexible
Kurve 180°

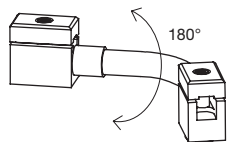

84966 **C**

Accessori

Accessori per binario applicazioni su vetrine
Show case accessories
Accessoires pour vitrines
Accesorios para vitrinas
Zubehör für Vitrinen

C 84978

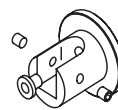
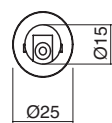
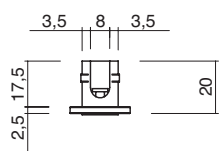

Attacco superiore
Higher connection / Supérieur fixation / Superior conexión / Höhere Verbindung

C 84977

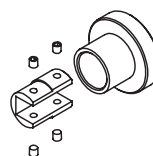
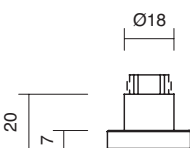

Attacco inferiore
Lower connection / Inférieur fixation / Inferior conexión / Niedriger Verbindung

84978

84977





Accessori con alimentazione
Accessories with power supply
Accessoires avec alimentation
Accesorios con alimentación
Zubehör mit Speisung

Giunzione lineare con alimentazione per binario sospeso
Linear coupling with power supply for suspended track / Jonction linéaire avec alimentation rail en suspension / Junta lineal con alimentación para riel colgante / Lineare Verbindung mit Speisung für hängende Schiene

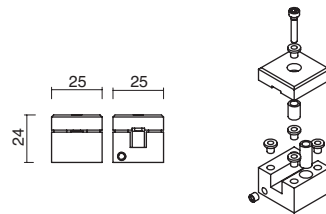

Base alimentazione per binario sospeso
Power supply base for suspended track / Base alimentation pour rail en suspension / Base alimentación para carril colgante / Speisungsbasis für hängende Schiene

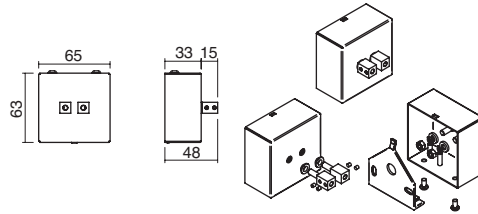

Base alimentazione per binario a filo
Power supply base for flush suspended track / Base alimentation pour rail à raz / Base alimentación para carril a ras / Speisungsbasis für bündige Schiene

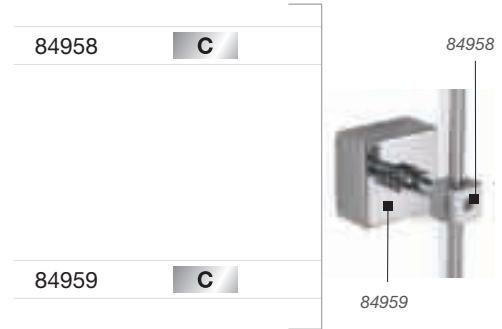
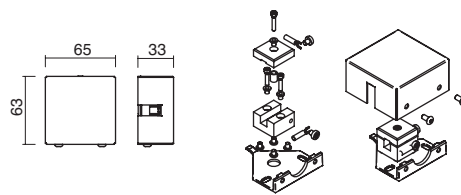

84965 C



84829
 Driver esterno
 External driver
 Driver extérieur
 Driver externo
 Außen Driver

84828
 Driver esterno
 External driver
 Driver extérieur
 Driver externo
 Außen Driver

vedi cap. Driver pag 808 Switching 24V DC
 See Driver section p. 808 Switching 24V DC
 Voir chapitre Drivers p. 808 Switching 24V DC
 Ver capitolo Driver p. 808 Switching 24V DC
 siehe Kap. "Driver" p. 808 Switching 24V DC

C driver incluso da 45 Watt 84980

Driver included 45 Watt
 Driver compris 45 Watt
 Driver incluido 45 Watt
 inklusive Driver 45 Watt

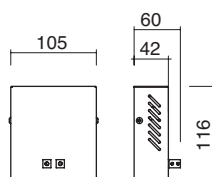
**C** driver incluso da 75 Watt 84981

Driver included 75 Watt
 Driver compris 75 Watt
 Driver incluido 75 Watt
 inklusive Driver 75 Watt

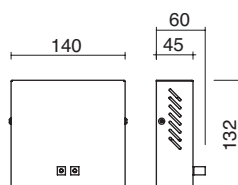

Accessori con alimentazione - Driver incluso
Accessories with power supply - Driver included
Accessoires avec alimentation - Driver compris
Accesorios con alimentación - Driver incluido
Zubehör mit Speisung - inklusive Driver

Base alimentazione per binario sospeso

Power supply base for suspended track
 Base alimentation pour rail en suspension
 Junta lineal con alimentación para riel a ras
 Speisungsbasis für hängende Schiene

**Illustrazione indicativa**

Indicative illustration
 Illustration indicatives
 Ilustracion indicativa
 Richtbildern

Da abbinare ad accessorio 84958

To be combined with accessory 84958
 À associer avec l'accessoire 84958.
 Para combinarse con el accesorio 84958.
 Mit dem Zubehör 84958 zu verbinden

C driver incluso da 45 Watt 84969

Driver included 45 Watt
 Driver compris 45 Watt
 Driver incluido 45 Watt
 inklusive Driver 45 Watt

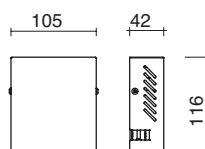
**C** driver incluso da 75 Watt 84968

Driver included 75 Watt
 Driver compris 75 Watt
 Driver incluido 75 Watt
 inklusive Driver 75 Watt

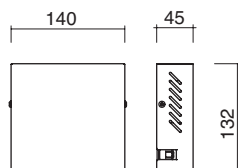
**Base alimentazione per binario a filo**

Power supply base for flush suspended track
 Base alimentation pour rail à raz
 Base alimentación para riel colgante
 Speisungsbasis für bündige Schiene

**Illustrazione indicativa**

Indicative illustration
 Illustration indicatives
 Ilustracion indicativa
 Richtbildern



Il pregio e la delicata manifattura di libri antichi vengono perfettamente rispettati e impreziositi dai led.

The value and the delicate workmanship of antique books are perfectly respected and set off by the led lights.

La valeur des livres anciens et leur manufacture délicate sont parfaitement respectées et enrichies par des leds.

El prestigio y la delicada manufactura de los libros antiguos son respetados y enriquecidos perfectamente por los leds.

Der Wert und die handwerkliche Herstellung antiker Bücher wird durch ein LED-System unterstrichen, ohne dass die empfindlichen Materialien Schaden nehmen.

Progetto: Ricostruzione vetrine espositive
Lighting Design: Linealight Group

*Project: Makeover of showcases
Lighting Design: Linealight Group*

*Projet: Reconstruction de vitrines présentaires
Design éclairage: Linealight Group*

*Proyecto: Restauración vitrinas de exposición
Lighting Design: LineaLight Group*

*Projekt: Aufbau von Ausstellungsvitrinen
Lighting Design: LineaLight Group*

Prodotti: Lisken 3led 1watt luce fredda
Sina 3led 1watt luce calda
Sina 2led 1watt luce calda

Products used: Lisken 3 leds 1 watt cold light, Sina 3 leds 1 watt warm light, Sina 2 leds 1 watt warm light

Produits: Lisken 3 leds 1 watts lumière froide, Sina 3 leds 1 watts lumière chaude, Sina 2 leds 1 watts lumière chaude

Productos: Lisken 3 leds 1 watt luz fría, Sina 3 leds 1 watt luz cálida, Sina 2 leds 1 watt luz cálida

Produkte: Lisken 3 led 1 Watt Kaltlicht, Sina 3 led 1 Watt Warmlicht, Sina 2 led 1 Watt Warmlicht

Per applicazioni simili si consiglia l'uso di articoli alimentati ad 1 Watt / For similar applications you are advised to use items powered by 1 Watt. / Pour des applications semblables, il est recommandé d'utiliser des articles avec alimentation à 1 Watt. / Para aplicaciones similares se recomienda la utilización de artículos alimentados con 1 Watt. / Für ähnliche Anwendungen empfehlen wir die Anwendung von mit 1 Watt gespeisten Artikeln.