

SPOT

SPOT

Corpo

in alluminio.

- Frame: In anodise aluminium.
- Gehäuse: Aus Aluminium.
- Corps: En aluminium.
- Cuerpo: en aluminio.



Molle

per incasso in controsoffitto.

- Springs: for flush mounting on false ceilings.
- Federn: zum Einsetzen in abgehängte Decken.
- Ressorts: pour encastrement sur faux-plafond.
- Muelle: para empotrado en falso techo.

Multichip

innovativo e performante circuito stampato da 2, 3, 6 e 9 led con ottica arretrata.

- Multichip: Innovative, high performance circuit board including 2, 3, 6 and 9 LEDs with recessed optics.
- Multichip: innovativer und leistungsstarker gedruckter Schaltkreis mit 2, 3, 6 und 9 LED und blendfreier Optik.
- Multichip: circuit estampé novateur et performant à 2, 3, 6 et 9 LEDs avec optique reculée.
- Multichip: innovador y circuito impreso de alto rendimiento de 2, 3, 6 y 9 LEDs con óptica trasera.

Monolente in cristallo

resa ottimale 70° e 120° ad alta definizione ridotto abbagliamento.

- Silicone cased single lens: excellent rendering. 70° and 120°, high definition reduced glaring effect.
- Einfachlinse aus Glas: optimale Lichtausbeute. 70° und 120° mit hoher Auflösung nicht blendend.
- Monolentille en cristal: rendement optimal. 70° et 120° à haute définition éblouissement réduit.
- Monolente en cristal: rendimiento óptimo. 70° y 120° a alta definición deslumbramiento reducido.

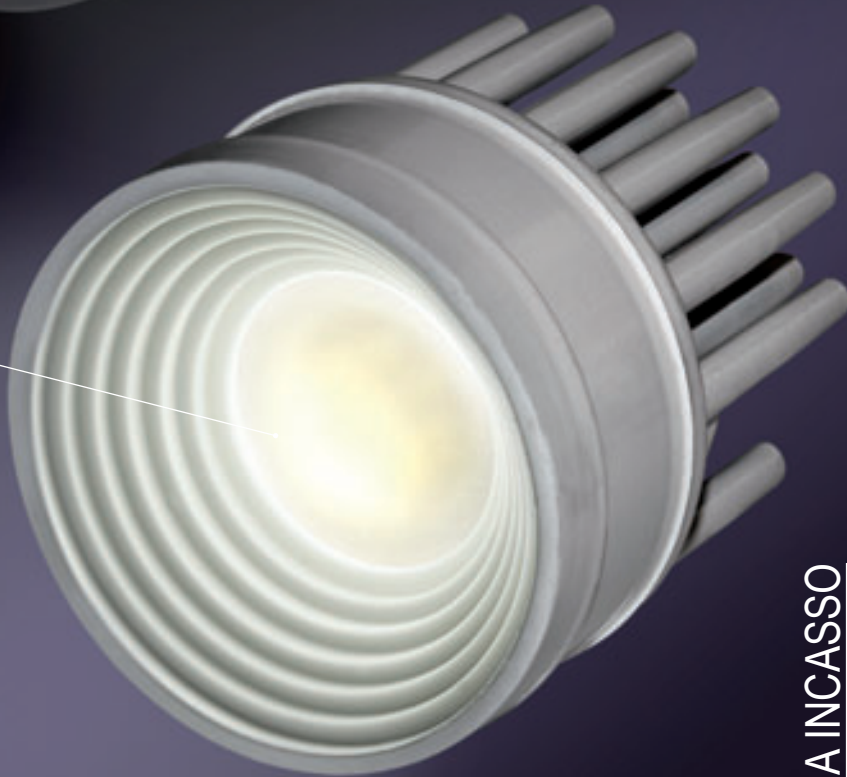

FARETTI DA INCASSO
RECESSED SPOTLIGHTS

SPOT RECESSED SPOTLIGHTS



FIXING

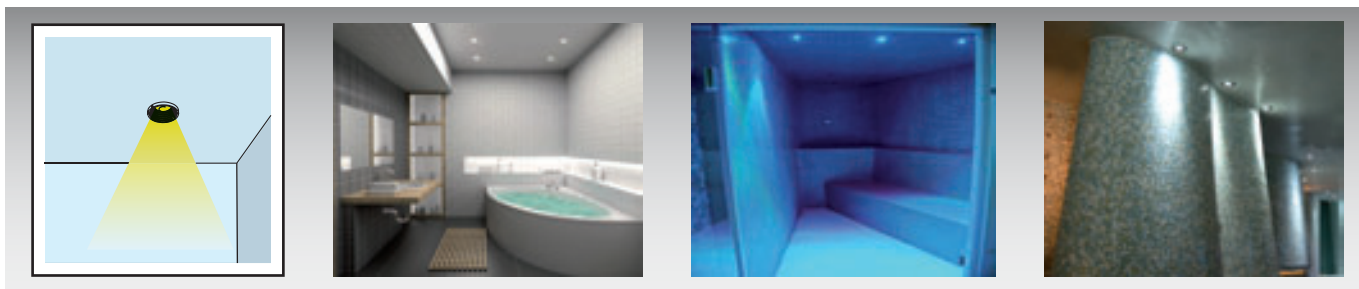

PHOTOMETRICAL CURVES

70°

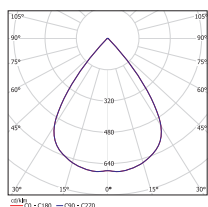

Le curve fotometriche si riferiscono ai 2 LED naturali e sono indicative
Photometric curves refer to the 2 LEDs Natural White and are indicative

120°

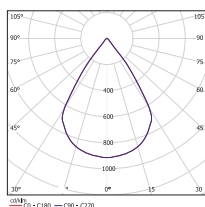

70°

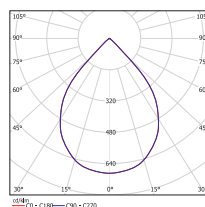

Le curve fotometriche si riferiscono ai 6 LED naturali e sono indicative
Photometric curves refer to the 6 LEDs Natural White and are indicative

120°

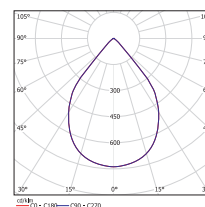

SUITABLE ELECTRONICS



LED CONTROLGEARS



→ 206

DRIVER EASY



→ 217

INTERFACES



→ 240

ANTON

MONO RGB



POWER: 2W
LEDs: 2
EMISSION: 70° - 120°
COLOUR: MONO, RGB
FINISHES: N, B, Ne
PROTECTION: MEDIUM (IP45)
OPTIC: FIXED

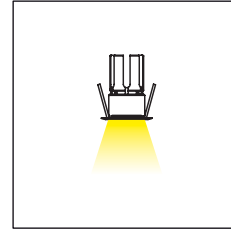

DIAMETER Ø
45 mm

AFFEL

MONO RGB



POWER: 2W
LEDs: 3
EMISSION: 70° - 120°
COLOUR: MONO, RGB
FINISHES: N, B, Ne
PROTECTION: MEDIUM (IP45)
OPTIC: FIXED

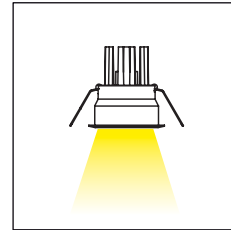

DIAMETER Ø
77 mm

ARENT

MONO RGB



POWER: 2W
LEDs: 6
EMISSION: 70° - 120°
COLOUR: MONO, RGB
FINISHES: N, B, Ne
PROTECTION: MEDIUM (IP45)
OPTIC: FIXED

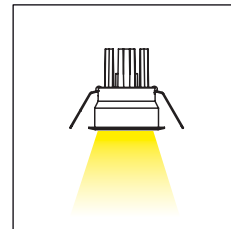

DIAMETER Ø
77 mm

ILLUM

MONO RGB



POWER: 2W
LEDs: 3
EMISSION: 70° - 120°
COLOUR: MONO, RGB
FINISHES: N, B, Ne
PROTECTION: LOW (IP40)
OPTIC: ADJUSTABLE

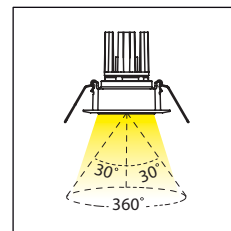

DIAMETER Ø
87 mm

TORY

MONO RGB



POWER: 2W
LEDs: 2
EMISSION: 70° - 120°
COLOUR: MONO, RGB
FINISHES: N, B, Ne
PROTECTION: MEDIUM (IP45)
OPTIC: FIXED

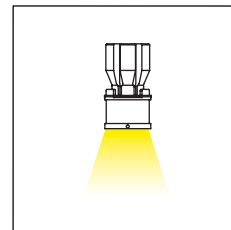

DIAMETER Ø
31 mm

THORN

MONO RGB



POWER: 2W
LEDs: 3
EMISSION: 70° - 120°
COLOUR: MONO, RGB
FINISHES: N, B, Ne
PROTECTION: MEDIUM (IP45)
OPTIC: FIXED

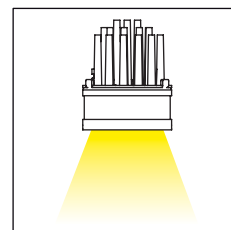

DIAMETER Ø
65 mm

TRAY

MONO RGB



POWER: 2W
LEDs: 6
EMISSION: 70° - 120°
COLOUR: MONO, RGB
FINISHES: N, B, Ne
PROTECTION: MEDIUM (IP45)
OPTIC: FIXED

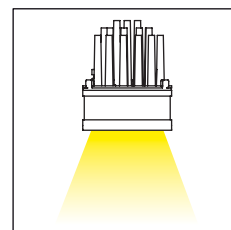

DIAMETER Ø
65 mm

ANTON

IP45

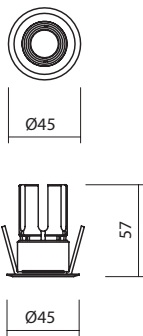

Proiettore da incasso a molle per controsoffitto. Ottica fissa. Garantisce un ottimo comfort visivo grazie ad una basetta multiLED arretrata su di un anello antiabbagliamento. Corpo in alluminio. Driver non compreso.

Recessed projector with springs for false ceiling, fixed optic. It guarantees an excellent visual comfort thanks to a leds mounted on an antiglaring ring. Aluminium body.

Einbauleuchte mit Federn für abgehängte Decken. Fixierte Optik. Durch die zurückgesetzte Multichip-Basis und den umfassenden Blendschutzring wird ein optimaler Sichtkomfort garantiert. Gehäuse aus Aluminium.

Projecteur à encastrer à ressort pour faux plafond avec optique fixe. Garantie un confort visuel optimal grâce a une plaque multiLED positionné derrière un anneau anti-éblouissement. Corps en Aluminium.

Proyector empotrable con muelles para falso techo. Óptica fija. Garantiza un óptimo confort visual gracias a una barra multiLED retrasada en un anillo anti deslumbramiento. Cuerpo en aluminio.

2 led 2W	Code
N	89290
B	89291
Ne	89292



Colours	Optical	Code	Accessories
● C	70°	70	
● W	120°	12	
● N			
● B			
● Y			
● R			
● G			

ANTON RGB

IP45

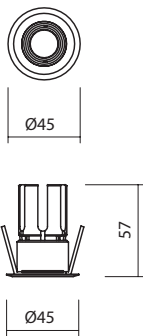

Proiettore da incasso a molle per controsoffitto. Ottica fissa. Garantisce un ottimo comfort visivo grazie ad una basetta multiLED arretrata su di un anello antiabbagliamento.
Corpo in alluminio.
Driver non compreso.

*Recessed projector with springs for false ceiling, fixed optic. It guarantees an excellent visual comfort thanks to a leds mounted on an antiglare ring.
Aluminium body.*

Einbauleuchte mit Federn für abgehängte Decken. Fixierte Optik. Durch die zurückgesetzte Multichip-Basis und den umfassenden Blendschutzring wird ein optimaler Sichtkomfort garantiert. Gehäuse aus Aluminium.

Projecteur à encastrer à ressort pour faux plafond avec optique fixe. Garantie un confort visuel optimal grâce a une plaque multiLED positionné derrière un anneaux anti-éblouissement. Corps en Aluminium.

Projector empotrable con muelles para falso techo. Óptica fija. Garantiza un óptimo confort visual gracias a una barra multiLED retrasada en un anillo anti deslumbramiento. Cuerpo en aluminio.

3 led 2W	Code
N	89305
B	89306
Ne	89307



Colours	Optical	Code	Accessories
● Z	70° 120°	70 12	

AFFEL

IP45

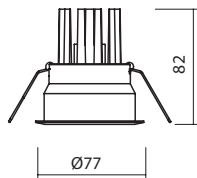
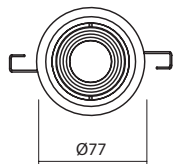

Proiettore da incasso a molle per controsoffitto. Ottica fissa. Garantisce un ottimo comfort visivo grazie ad una basetta multiLED arretrata su di un anello antiabbagliamento. Corpo in alluminio. Driver non compreso.

Recessed projector with springs for false ceiling, fixed optic. It guarantees an excellent visual comfort thanks to a leds mounted on an antiglaring ring. Aluminium body.

Einbauleuchte mit Federn für abgehängte Decken. Fixierte Optik. Blendschutzring wird ein optimaler Sichtkomfort garantiert. Gehäuse aus Aluminium.

Projecteur à encastrer à ressort pour faux plafond avec optique fixe. Garantie un confort visuel optimal grâce a une plaque multiLED positionné derrière un anneau anti-éblouissement. Corps en Aluminium.

Proyector empotrable con muelles para falso techo. Óptica fija. Garantiza un óptimo confort visual gracias a una barra multiLED retrasada en un anillo anti deslumbramiento. Cuerpo en aluminio.

3 led 2W	Code
N	89349
B	89350
Ne	89351



Colours	Optical	Code	Accessories
<ul style="list-style-type: none"> ● C ● W ● N ● B ● Y ● R ● G 	70° 120°	70 12	<div style="display: flex; justify-content: space-around;"> <div style="border: 1px solid black; padding: 5px; text-align: center;"> <p>CONTROCASSA OUTER-CASING</p> <p>89373 183</p> </div> <div style="border: 1px solid black; padding: 5px; text-align: center;"> <p>CONTROCASSA OUTER-CASING</p> <p>89374 183</p> </div> </div>

AFFEL RGB

IP45

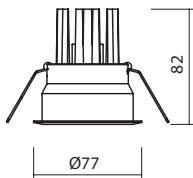
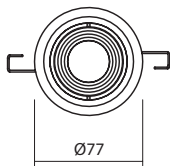

Proiettore da incasso a molle per controsoffitto. Ottica fissa. Garantisce un ottimo comfort visivo grazie ad una basetta multiled arretrata su di un anello antiabbagliamento.
Corpo in alluminio.
Driver non compreso.

*Recessed projector with springs for false ceiling, fixed optic. It guarantees an excellent visual comfort thanks to a leds mounted on an antiglaring ring.
Aluminium body.*

Einbauleuchte mit Federn für abgehängte Decken. Fixierte Optik. Blendschutzring wird ein optimaler Sichtkomfort garantiert. Gehäuse aus Aluminium.

Projecteur à encastrer à ressort pour faux plafond avec optique fixe. Garantie un confort visuel optimal grâce a une plaque multiLED positionné derrière un anneau anti-éblouissement. Corps en Aluminium.

Proyector empotrable con muelles para falso techo. Óptica fija. Garantiza un óptimo confort visual gracias a una barra multiled retrasada en un anillo anti deslumbramiento. Cuerpo en aluminio.

3 led 2W	Code
N	89355
B	89356
Ne	89357



Colours	Optical	Code	Accessories
Z	70° 120°	70 12	<p>CONTROCASSA OUTER-CASING</p> <p>89373 183</p>

ARENT IP45

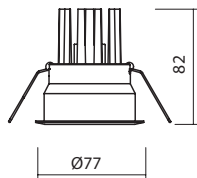
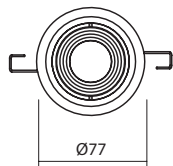

Proiettore da incasso a molle per controsoffitto. Ottica fissa. Garantisce un ottimo comfort visivo grazie ad una basetta multiLED arretrata su di un anello antiabbagliamento.
Corpo in alluminio.
Driver non compreso.

*Recessed projector with springs for false ceiling, fixed optic. It guarantees an excellent visual comfort thanks to a leds mounted on an antiglaring ring.
Aluminium body.*

*Einbauleuchte mit Federn für abgehängte Decken. Fixierte Optik. Blendschutzring wird ein optimaler Sichtkomfort garantiert.
Gehäuse aus Aluminium.*

*Projecteur à encastrer à ressort pour faux plafond avec optique fixe. Garantie un confort visuel optimal grâce a une plaque multiLED positionné derrière un anneaux anti-éblouissement.
Corps en Aluminium.*

*Proyector empotrable con muelles para falso techo. Óptica fija. Garantiza un óptimo confort visual gracias a una barra multiLED retrasada en un anillo anti deslumbramiento.
Cuerpo en aluminio.*

6 led 2W	Code
N	89296
B	89297
Ne	89298



Colours	Optical	Code	Accessories
<ul style="list-style-type: none"> ● C ● W ● N ● B ● Y ● R ● G 	<ul style="list-style-type: none"> 70° 120° 	<ul style="list-style-type: none"> 70 12 	<div style="border: 1px solid black; padding: 5px;"> <p>CONTROCASSA OUTER-CASING</p> <p>89373 </p> </div>

ARENT RGB

IP45

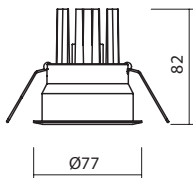
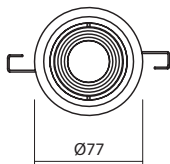

Proiettore da incasso a molle per controsoffitto. Ottica fissa. Garantisce un ottimo comfort visivo grazie ad una basetta multiLED arretrata su di un anello antiabbagliamento.
Corpo in alluminio.
Driver non compreso.

*Recessed projector with springs for false ceiling, fixed optic. It guarantees an excellent visual comfort thanks to a leds mounted on an antiglaring ring.
Aluminium body.*

*Einbauleuchte mit Federn für abgehängte Decken. Fixierte Optik. Blendschutzring wird ein optimaler Sichtkomfort garantiert.
Gehäuse aus Aluminium.*

*Projecteur à encastrer à ressort pour faux plafond avec optique fixe. Garantie un confort visuel optimal grâce a une plaque multiLED positionné derrière un anneau anti-éblouissement.
Corps en Aluminium.*

*Proyector empotrable con muelles para falso techo. Óptica fija. Garantiza un óptimo confort visual gracias a una barra multiLED retrasada en un anillo anti deslumbramiento.
Cuerpo en aluminio.*

6 led 2W	Code
N	89311
B	89312
Ne	89313



Colours	Optical	Code	Accessories
Z	70° 120°	70 12	<div style="border: 1px solid black; padding: 5px;"> <p>CONTROCASSA OUTER-CASING</p> <p>89373 183</p> </div>

ILLUM

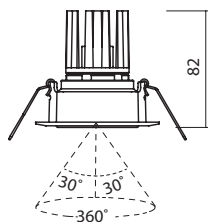
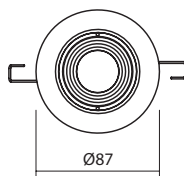

Proiettore da incasso a molle per controsoffitto. Ottica basculante. Garantisce un ottimo comfort visivo grazie ad una basetta multiLED arretrata su di un anello antiabbagliamento.
Corpo in alluminio.
Driver non compreso.

*Recessed projector with springs for false ceiling, fixed optic. It guarantees an excellent visual comfort thanks to a leds mounted on an antiglaring ring.
Aluminium body.*

*Einbauleuchte mit Federn für abgehängte Decken. Fixierte Optik. Blendschutzring wird ein optimaler Sichtkomfort garantiert.
Gehäuse aus Aluminium.*

*Projecteur à encastrer à ressort pour faux plafond avec optique fixe. Garantie un confort visuel optimal grâce a une plaque multiLED positionné derrière un anneaux anti-éblouissement.
Corps en Aluminium.*

*Proyector empotrable con muelles para falso techo. Óptica fija. Garantiza un óptimo confort visual gracias a una barra multiLED retrasada en un anillo anti deslumbramiento.
Cuerpo en aluminio.*

3 led 2W	Code
N	89340
B	89341
Ne	89342



Colours	Optical	Code	Accessories
<ul style="list-style-type: none"> ● C ● W ● N ● B ● Y ● R ● G 	70° 120°	70 12	<div style="display: flex; justify-content: space-around;"> <div style="border: 1px solid black; padding: 5px; text-align: center;"> <p>CONTROCASSA OUTER-CASING</p>  <p>89373  183</p> </div> <div style="border: 1px solid black; padding: 5px; text-align: center;"> <p>CONTROCASSA OUTER-CASING</p>  <p>89374  183</p> </div> </div>

ILLUM RGB



Proiettore da incasso a molle per controsoffitto. Ottica basculante. Garantisce un ottimo comfort visivo grazie ad una bassetta multiLED arretrata su di un anello antiabbagliamento.
Corpo in alluminio.
Driver non compreso.

*Recessed projector with springs for false ceiling, fixed optic. It guarantees an excellent visual comfort thanks to a leds mounted on an antiglare ring.
Aluminium body.*

*Einbauleuchte mit Federn für abgehängte Decken. Fixierte Optik. Blendschutzring wird ein optimaler Sichtkomfort garantiert.
Gehäuse aus Aluminium.*

*Projecteur à encastrer à ressort pour faux plafond avec optique fixe. Garantie un confort visuel optimal grâce a une plaque multiLED positionné derrière un anneau anti-éblouissement.
Corps en Aluminium.*

*Proyector empotrable con muelles para falso techo. Óptica fija. Garantiza un óptimo confort visual gracias a una barra multiLED retrasada en un anillo anti deslumbramiento.
Cuerpo en aluminio.*

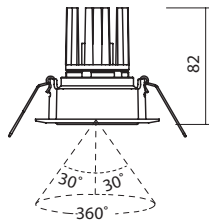
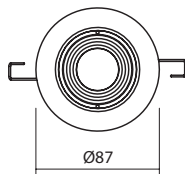

3 led 2W	Code
N	89343
B	89344
Ne	89345



Colours	Optical	Code	Accessories
Z	70° 120°	70 12	<p>CONTROCASSA OUTER-CASING</p> <p>89373 183</p>

TORY

IP45

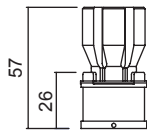

Proiettore da incasso a molle per controsoffitto. Ottica fissa. Garantisce un ottimo comfort visivo grazie ad una basetta multiLED arretrata su di un anello antiabbagliamento.
Corpo in alluminio "frame-less".
Driver non compreso.

*Recessed projector with springs for false ceiling, fixed optic. It guarantees an excellent visual comfort thanks to a leds mounted on an antiglaring ring.
Aluminium body "frame-less".*

*Einbauleuchte mit Federn für abgehängte Decken. Fixierte Optik. Blendschutzring wird ein optimaler Sichtkomfort garantiert.
Gehäuse aus Aluminium "frame-less".*

*Projecteur à encastrer à ressort pour faux plafond avec optique fixe. Garantie un confort visuel optimal grâce a une plaque multiLED positionné derrière un anneau anti-éblouissement.
Corps en Aluminium "frame-less".*

*Proyector empotrable con muelles para falso techo. Óptica fija. Garantiza un óptimo confort visual gracias a una barra multiLED retrasada en un anillo anti deslumbramiento.
Cuerpo en aluminio "frame-less".*

2 led 2W	Code
N	89299
B	89300
Ne	89301



Colours	Optical	Code	Accessories
<ul style="list-style-type: none"> ● C ● W ● N ● B ● Y ● R ● G 	70° 120°	70 12	<div style="display: flex; justify-content: space-between;"> <div style="width: 30%;"> <p>CONTROCASSA FILETTATA THREADED OUTER-CASING</p>  <p>89389 </p> </div> <div style="width: 30%;"> <p>MOLLA PER FISSAGGIO FIXING SPRING</p>  <p>INCLUDED</p> </div> <div style="width: 30%;"> <p>CHIAVE PER RIMOZIONE REMOVAL</p>  <p>INCLUDED</p> </div> </div>

TORY RGB

IP45

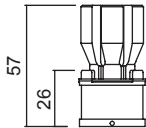

Proiettore da incasso a molle per controsoffitto. Ottica fissa. Garantisce un ottimo comfort visivo grazie ad una basetta multiLED arretrata su di un anello antiabbagliamento.

Corpo in alluminio "frame-less".
Driver non compreso.

*Recessed projector with springs for false ceiling, fixed optic. It guarantees an excellent visual comfort thanks to a leds mounted on an antiglaring ring.
Aluminium body "frame-less".*

*Einbauleuchte mit Federn für Hängedecke. Fixierte Optik. Blendschutzring wird ein optimaler Sichtkomfort garantiert.
Gehäuse aus Aluminium "frame-less".*

*Projecteur à encastrer à ressort pour faux plafond avec optique fixe. Garantie un confort visuel optimal grâce a une plaque multiLED positionné derrière un anneau anti-éblouissement.
Corps en Aluminium "frame-less".*

*Proyector empotrable con muelles para falso techo. Óptica fija. Garantiza un óptimo comfort visual gracias a una barra multiLED retrasada en un anillo anti deslumbramiento.
Cuerpo en aluminio "frame-less".*

3 led 2W	Code
N	89314
B	89315
Ne	89316



Colours	Optical	Code	Accessories
Z	70° 120°	70 12	<div style="display: flex; justify-content: space-between;"> <div style="width: 30%;"> <p>CONTROCASSA FILETTATA THREADED OUTER-CASING</p>  <p>89389</p> </div> <div style="width: 30%;"> <p>MOLLA PER FISSAGGIO FIXING SPRING</p>  <p>INCLUDED</p> </div> <div style="width: 30%;"> <p>CHIAVE PER RIMOZIONE REMOVAL</p>  <p>INCLUDED</p> </div> </div>

THORN

IP45

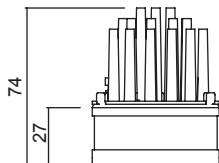
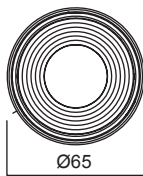

Proiettore da incasso a molle per controsoffitto. Ottica fissa. Garantisce un ottimo comfort visivo grazie ad una basetta multiLED arretrata su di un anello antiabbagliamento.
Corpo in alluminio "frame-less".
Driver non compreso.

*Recessed projector with springs for false ceiling, fixed optic. It guarantees an excellent visual comfort thanks to a leds mounted on an antiglaring ring.
Aluminium body "frame-less".*

Einbauleuchte mit Federn für Hängendecke. Fixierte Optik. Blendschutzring wird ein optimaler Sichtkomfort garantiert. Gehäuse aus Aluminium "frame-less".

Projecteur à encastrer à ressort pour faux plafond avec optique fixe. Garantie un confort visuel optimal grâce a une plaque multiLED positionné derrière un anneau anti-éblouissement. Corps en Aluminium "frame-less".

Proyector empotrable con muelles para falso techo. Óptica fija. Garantiza un óptimo confort visual gracias a una barra multiLED retrasada en un anillo anti deslumbramiento. Cuerpo en aluminio "frame-less".

3 led 2W	Code
N	89379
B	89380
Ne	89381



Colours	Optical	Code	Accessories
<ul style="list-style-type: none"> ● C ● W ● N ● B ● Y ● R ● G 	70° 120°	70 12	<div style="display: flex; justify-content: space-between;"> <div style="width: 30%;"> <p>CONTROCASSA FILETTATA THREADED OUTER-CASING</p> <p>89388 182</p> </div> <div style="width: 30%;"> <p>MOLLA PER FISSAGGIO FIXING SPRING</p> <p>INCLUDED</p> </div> <div style="width: 30%;"> <p>CHIAVE PER RIMOZIONE REMOVAL</p> <p>INCLUDED</p> </div> </div>

THORN RGB

IP45

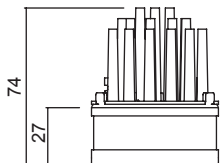
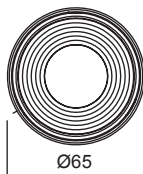

Proiettore da incasso a molle per controsoffitto. Ottica fissa. Garantisce un ottimo comfort visivo grazie ad una basetta multiLED arretrata su di un anello antiabbagliamento.
Corpo in alluminio "frame-less".
Driver non compreso.

*Recessed projector with springs for false ceiling, fixed optic. It guarantees an excellent visual comfort thanks to a leds mounted on an antiglaring ring.
Aluminium body "frame-less".*

Einbauleuchte mit Federn für Hängedeeke. Fixierte Optik. Blendschutzring wird ein optimaler Sichtkomfort garantiert. Gehäuse aus Aluminium "frame-less".

Projecteur à encastrer à ressort pour faux plafond avec optique fixe. Garantie un confort visuel optimal grâce a une plaque multiLED positionné derrière un aneaux anti-éblouissement. Corps en Aluminium "frame-less".

Proyector empotrable con muelles para falso techo. Óptica fija. Garantiza un óptimo comfort visual gracias a una barra multiLED retrasada en un anillo anti deslumbramiento. Cuerpo en aluminio "frame-less".

THORN RGB

3 led 2W	Code
N	89382
B	89383
Ne	89384



Colours	Optical	Code	Accessories
Z	70° 120°	70 12	<div style="display: flex; justify-content: space-between;"> <div style="width: 30%;"> <p>CONTROCASSA FILETTATA THREADED OUTER-CASING</p>  <p>89388</p> </div> <div style="width: 30%;"> <p>MOLLA PER FISSAGGIO FIXING SPRING</p>  <p>INCLUDED</p> </div> <div style="width: 30%;"> <p>CHIAVE PER RIMOZIONE REMOVAL</p>  <p>INCLUDED</p> </div> </div>

TRAY

IP45

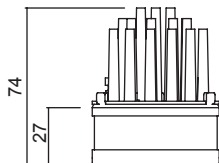
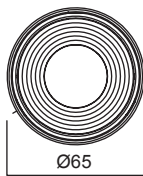

Proiettore da incasso a molle per controsoffitto. Ottica fissa. Garantisce un ottimo comfort visivo grazie ad una basetta multiLED arretrata su di un anello antiabbagliamento. Corpo in alluminio "frame-less". Driver non compreso.

Recessed projector with springs for false ceiling, fixed optic. It guarantees an excellent visual comfort thanks to a leds mounted on an antiglaring ring. Aluminium body "frame-less".

Einbauleuchte mit Federn für Hängedecke. Fixierte Optik. Blendschutzring wird ein optimaler Sichtkomfort garantiert. Gehäuse aus Aluminium "frame-less".

Projecteur à encastrer à ressort pour faux plafond avec optique fixe. Garantie un confort visuel optimal grâce a une plaque multiLED positionné derrière un anneau anti-éblouissement. Corps en Aluminium "frame-less".

Proyector empotrable con muelles para falso techo. Óptica fija. Garantiza un óptimo confort visual gracias a una barra multiLED retrasada en un anillo anti deslumbramiento. Cuerpo en aluminio "frame-less".

6 led 2W	Code
N	89302
B	89303
Ne	89304



Colours	Optical	Code	Accessories
<ul style="list-style-type: none"> ● C ● W ● N ● B ● Y ● R ● G 	70° 120°	70 12	<div style="display: flex; justify-content: space-between;"> <div style="width: 30%;"> <p>CONTROCASSA FILETTATA THREADED OUTER-CASING</p>  <p>89388 </p> </div> <div style="width: 30%;"> <p>MOLLA PER FISSAGGIO FIXING SPRING</p>  <p>INCLUDED</p> </div> <div style="width: 30%;"> <p>CHIAVE PER RIMOZIONE REMOVAL</p>  <p>INCLUDED</p> </div> </div>

TRAY RGB

IP45

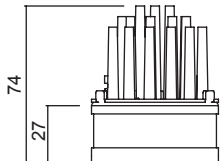
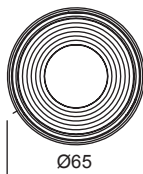

Proiettore da incasso a molle per controsoffitto. Ottica fissa. Garantisce un ottimo comfort visivo grazie ad una basetta multiLED arretrata su di un anello antiabbagliamento.
Corpo in alluminio "frame-less".
Driver non compreso.

*Recessed projector with springs for false ceiling, fixed optic. It guarantees an excellent visual comfort thanks to a leds mounted on an antiglaring ring.
Aluminium body "frame-less".*

Einbauleuchte mit Federn für Hängedeeke. Fixierte Optik. Blendschutzring wird ein optimaler Sichtkomfort garantiert. Gehäuse aus Aluminium "frame-less".

Projecteur à encastrer à ressort pour faux plafond avec optique fixe. Garantie un confort visuel optimal grâce a une plaque multiLED positionné derrière un anneau anti-éblouissement. Corps en Aluminium "frame-less".

Proyector empotrable con muelles para falso techo. Óptica fija. Garantiza un óptimo confort visual gracias a una barra multiLED retrasada en un anillo anti deslumbramiento. Cuerpo en aluminio "frame-less".

TRAY RGB

6 led 2W	Code
N	89317
B	89318
Ne	89319



Colours	Optical	Code	Accessories
Z	70° 120°	70 12	<div style="display: flex; justify-content: space-between;"> <div style="width: 30%;"> <p>CONTROCASSA FILETTATA THREADED OUTER-CASING</p>  <p>89388 </p> </div> <div style="width: 30%;"> <p>MOLLA PER FISSAGGIO FIXING SPRING</p>  <p>INCLUDED</p> </div> <div style="width: 30%;"> <p>CHIAVE PER RIMOZIONE REMOVAL</p>  <p>INCLUDED</p> </div> </div>

ACCESSORIES

CONTROCASSE PER FARETTI FRAME-LESS / RECESSED HOUSINGS FOR FRAME-LESS SPOTLIGHTS

Controcasse in alluminio con filettatura necessarie per l'installazione.
Comprehensive di chiave.

Aluminium recessed housings with threading necessary for the installation.
Key included.

TECHNICAL DATA

Ø	Code
35 mm	89389

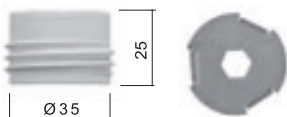

Ø	Code
61 mm	89388

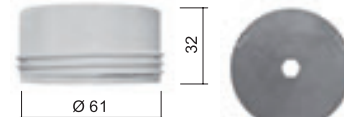

INSTALLATION

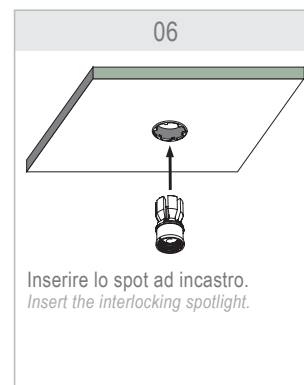
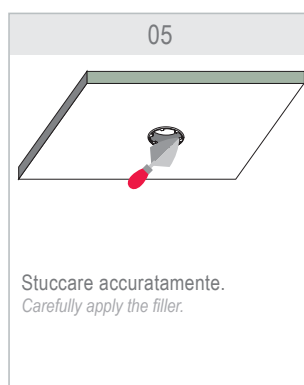
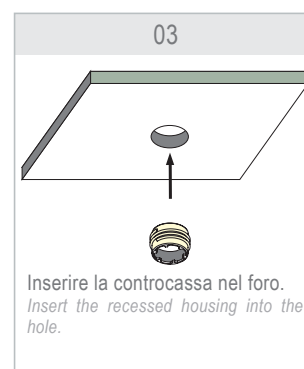
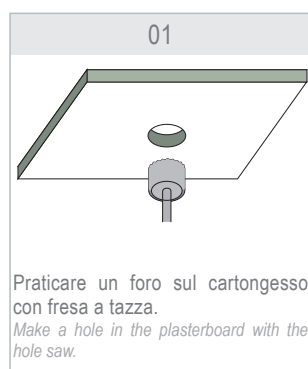

REMOVAL

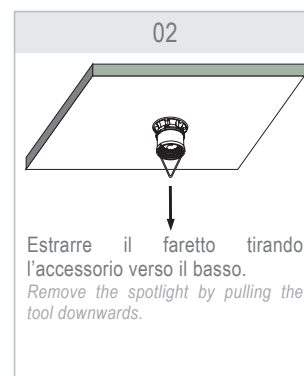
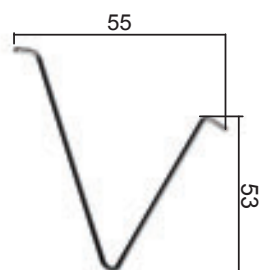

INCLUDED

ACCESSORIES

CONTROCASSE PER INSTALLAZIONE SU MURATURA / RECESSED HOUSINGS FOR INSTALLATION ON BRICKWORK

Scatole porta faretto in polipropilene.

Scatole porta faretto in polipropilene.

TECHNICAL DATA

Scatola porta faretto.
Spotlight holders

Code 89373

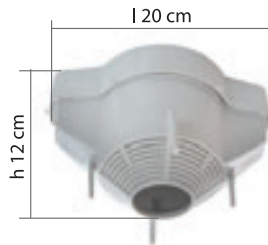

Porta faretto e alimentatore.*
Spotlight and power supply holders.*

Code 89374

* Può contenere solo alimentatore 1-3 led
* It can only contain 1-3 LED driver.

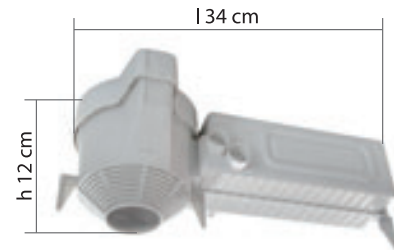

INSTALLATION

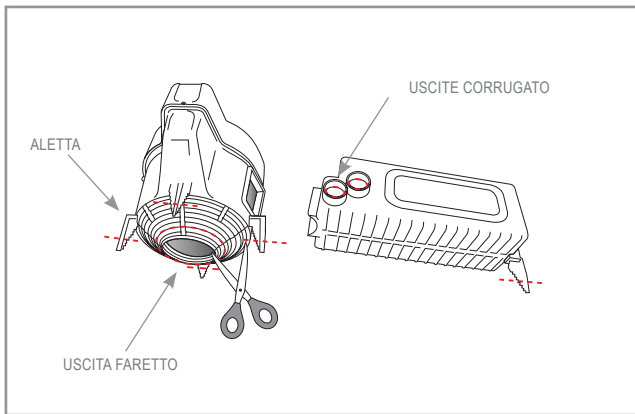

Tagliare l'apertura della contracassa per ottenere un foro di diametro utile all'installazione.

Tagliare poi alla stessa altezza le alette di appoggio per portarle allo stesso livello.

Cut out the recessed housing's opening, so as to obtain a hole of suitable diameter. Cut the supporting fins at the same height, so as to bring them to the same level.

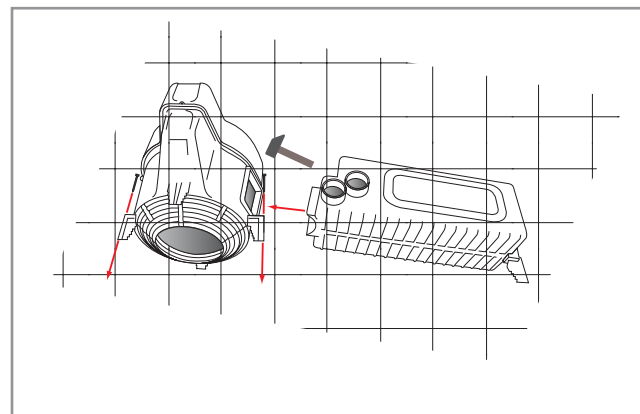

Fissare la contracassa alla cassaforma inserendo due chiodi nelle alette (nella versione COD, inserire il porta alimentatore nella contracassa). Opzionale: legare la contracassa con del filo metallico ai ferri dell'armatura.

Fasten the recessed housing onto the framework by inserting two nails in the fins (in the COD version, insert the power supply unit into the recessed housing). Optional: tie the recessed housing to the girder by means of metal wire.

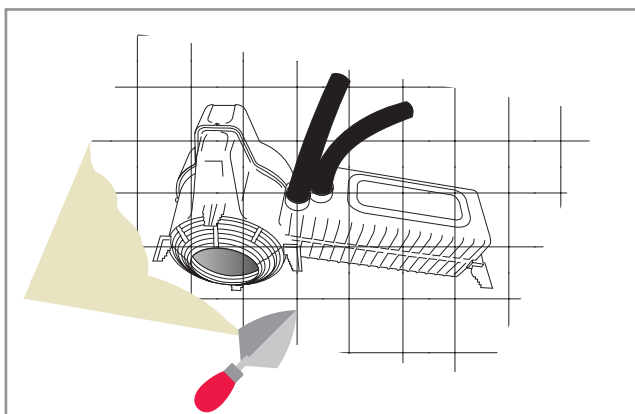

Predisporre i cavi per l'alimentazione e sigillare le fessure presenti nella contracassa con colla siliconica, quindi procedere con la gettata.

Arrange the power supply cables and seal the gaps on the recessed housing using silicone glue; then carry out the casting.

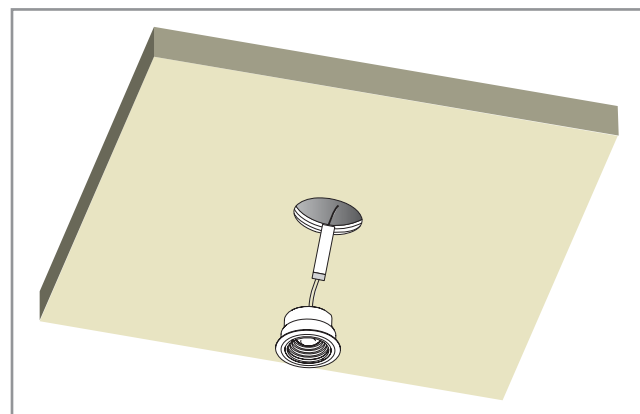

Inserire alimentatore e faretto nella contracassa.

Insert the power supply unit and spotlight in the recessed housing.