

CAP06 è - living inside

Proiettori orientabili da 9, 12 e 18 Led 2 watt disponibili nelle versioni Monocromatico, Bianco Dinamico ed RGB. Costruiti per essere installati sul sistema a canali Track System o Dynamik Track. Sono forniti di elettronica interna e telecomando IR, che usa il protocollo DMX. Installando a monte una unità Master riusciamo a pilotare un massimo di 32 proiettori con Touch Screen o Driver Master RGB. Tutti gli accessori del binario sono presenti nel catalogo della Traddel società appartenente al gruppo Linea Light.

Directional 9, 12 and 18 leds, 2 watt spotlights available in the White, Dynamic White and RGB versions. Constructed to be installed on the Track System or Dynamik Track. They are supplied with internal electronics and IR remote control that uses the DMX protocol.

By installing a Master unit we are able to control from a maximum of 32 spotlights by means of the Touch Screen or the RGB Master Driver. You can find all the track accessories in the Traddel catalogue, a company that belongs to the Linea Light group.

Des projecteurs orientables à 9, 12 et 18 Leds 2 watts, sont disponibles dans les versions Blanc, Blanc Dynamique et RGB. Conçus pour être installés sur le système à canaux Track System ou Dynamik Track, ils sont dotés d'éléments électroniques intérieurs et d'une télécommande IR, utilisant le protocole DMX.

En installant en amont une unité maîtresse, on arrive à piloter maximum 32 projecteurs avec Touch screen ou Driver Master RGB. Vous pouvez trouver tous les accessoires du rail dans le catalogue de la société Traddel qui fait partie du groupe Linea Light.

Proyectors orientables de 9, 12 y 18 leds 2 watt disponibles en las versiones blanco, blanco dinámico y RGB. Fabricados para su incorporación al sistema de canales Track System o Dynamik Track están dotados con electrónica interior y control remoto por infrarrojos, que emplea el protocolo DMX.

Si antes se instala una unidad Master es posible controlar desde como máximo 32 proyectores con Touch Screen o con Driver Master RGB. Todos los accesorios del rail se pueden encontrar en el catálogo de Traddel, sociedad que forma parte del grupo Linea Light.

Schwenkbare Strahler mit 9, 12 und 18 LED 2 Watt, in den Versionen Weiß, Superweiß und RGB. Für die Installation auf dem Schienensystem Track System oder Dynamik Track vorgesehen und mit Innenelektronik und einer IR-Fernbedienung mit DMX-Protokoll ausgestattet.

Durch den vorgeschalteten Einbau einer Mastereinheit können maximal 32 Scheinwerfer mit Touch Screen oder mit Master RGB-Steuergerät verwaltet werden. Das gesamte Zubehör des Schienensystems finden Sie im Katalog von Traddel, einer zur Linea Light Group gehörenden Gesellschaft.



BIANCO FREDDO 6000°K
RESA CROMATICA 70 (CRI)
COLD WHITE 6000°K
COLOUR REPRODUCTION 70 (CRI)
BLANC FROID 6000°K
RENDU CHROMATIQUE 70 (CRI)
BLANCO FRÍO 6000°K
RENDIMIENTO CROMÁTICO 70 (CRI)
KALTWEISS 6000°K
FARBWIEDERGABEINDEX (CRI 70)



BIANCO NATURALE 3700°K
RESA CROMATICA (CRI 75)
NATURAL WHITE 3700°K
COLOUR REPRODUCTION (CRI 75)
BLANC NATUREL 3700°K
RENDU CHROMATIQUE (CRI 75)
BLANCO NATURAL 3700°K
RENDIMIENTO CROMÁTICO 75 (CRI)
NEUTRALWEISS 3700°K
FARBWIEDERGABEINDEX (CRI 75)



BIANCO CALDO 2800°K
RESA CROMATICA (CRI 80)
WARM WHITE 2800°K
COLOUR REPRODUCTION (CRI 80)
BLANC CHAUD 2800°K
RENDU CHROMATIQUE (CRI 80)
BLANCO CÁLIDO 2800°K
RENDIMIENTO CROMÁTICO 80 (CRI)
WARMWEISS 2800°K
FARBWIEDERGABEINDEX (CRI 80)

Borsa in dettaglio: esempio pratico di come enfatizzare il valore dell'oggetto stesso.
Close-up view of the bag: a practical example of how to bring out the value of the object itself / Détail du sac: exemple pratique de mise en valeur d'un objet / Bolsa en detalle: ejemplo práctico de cómo enfatizar el valor del propio objeto / Tasche im Detail: ein Praxisbeispiel, wie der Wert des Gegenstands selbst hervorgehoben werden kann.



BIANCO FREDDO 6000°K
 COLD WHITE 6000°K
 BLANC FROID 6000°K
 BLANCO FRÍO 6000°K
 KALTWEISS 6000°K



BIANCO NATURALE 3700°K
 NATURAL WHITE 3700°K
 BLANC NATUREL 3700°K
 BLANCO NATURAL 3700°K
 NEUTRALWEISS 3700°K



BIANCO CALDO 2800°K
 WARM WHITE 2800°K
 BLANC CHAUD 2800°K
 BLANCO CÁLIDO 2800°K
 WARMWEISS 2800°K

Retail: mode e tendenze che si susseguono a ritmi incalzanti. Ogni colore per rendere al massimo ha bisogno della sua luce, ogni forma si mette in risalto grazie ad effetti mirati di luce calcolata. Oggi grazie alla potenza del bianco dinamico, possiamo vestire di fascino gli oggetti, dare a loro un richiamo irresistibile.

Prodotti: Edwin da 2 watt in bianco dinamico

Retail: fashion and trends chase each other at a pressing pace. Every colour needs light to be displayed at its best, every shape is set off thanks to focused effects of calculated light. Thanks to the power of dynamic white, we can now envelop objects with charm to give them an irresistible charm.

Products used: Edwin 2 watt in dynamic white

Vente au détail: la mode et les tendances changent à des rythmes pressants. Chaque coloris, pour rendre au mieux, a besoin d'un éclairage spécial, chaque forme est mise en relief grâce aux effets de lumière spéciaux orientés. Aujourd'hui, grâce à la puissance du blanc dynamique, les objets peuvent se revêtir de charme et lancer un rappel irrésistible.

Produits: Edwin de 2 watts en blanc dynamique

Retail: modas y tendencias que se suceden con ritmos apremiantes. Cualquier color para su máximo rendimiento precisa de su propia luz, cualquier forma destaca gracias a los efectos calculados de la luz direccionable. Hoy día, gracias a la potencia del blanco dinámico, podemos llenar de atractivo los objetos, volviéndolos llamativos.

Productos: Edwin de 2 watt en blanco dinámico

Retail: Moden und Tendenzen folgen im überstürzenden Rhythmus aufeinander. Jede Farbe braucht zur vollen Entfaltung ihr ganz persönliches Licht, jede Form wird durch gezielte Lichteffekte optimal hervorgehoben. Die innovative Leuchtkraft von Superweiß verstärkt die Ausstrahlung der Gegenstände und schenkt ihnen eine unwiderstehliche Wirkung.

Produkte: Edwin 2 Watt in Superweiß

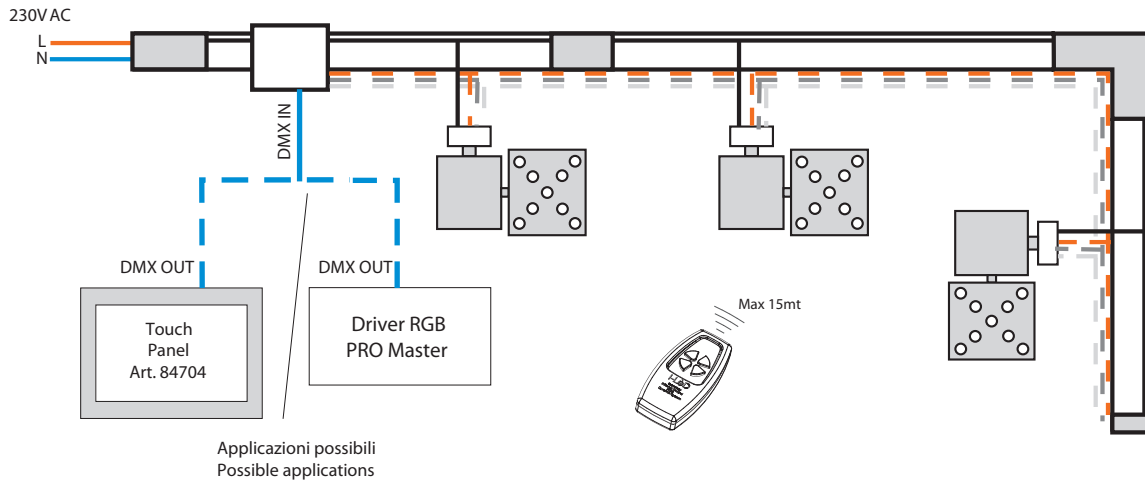

Per i modelli RGB e Dynamic White usare binario Dynamic Track.
 Use Dynamic Track for the RGB and Dynamic White models.
 Pour les modèles RGB et Dynamic White, utiliser le rail Dynamic Track.
 Para los modelos RGB y Dynamic White utilizar el riel Dynamic Track.
 Für die Modelle RGB und Dynamic White ist die Schiene Dynamic Track zu verwenden.

Per i modelli Monocromatici usare binario Track System.
 Use the Track System track for the monochromatic models.
 Pour les modèles monochromes, utiliser le rail Track System.
 Para los modelos Monocromatici utilizar el riel Track System.
 Für die einfarbigen Modelle ist die Schiene Track System zu verwenden.

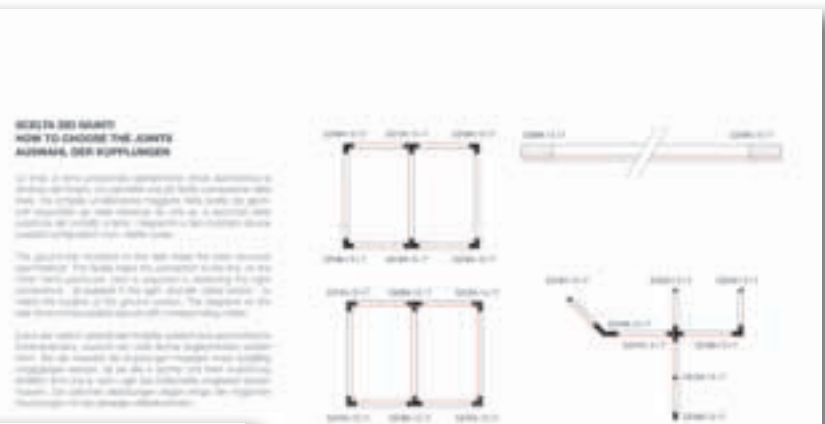

Track System							
	<table border="1"> <tr><td>SP214</td><td>SP215</td><td>SP216</td></tr> <tr><td>SP217</td><td>SP218</td><td>SP219</td></tr> </table>	SP214	SP215	SP216	SP217	SP218	SP219
SP214	SP215	SP216					
SP217	SP218	SP219					
	<table border="1"> <tr><td>SP220</td><td>SP221</td><td>SP222</td></tr> <tr><td>SP223</td><td>SP224</td><td>SP225</td></tr> </table>	SP220	SP221	SP222	SP223	SP224	SP225
SP220	SP221	SP222					
SP223	SP224	SP225					
	<table border="1"> <tr><td>SP226</td><td>SP227</td><td>SP228</td></tr> <tr><td>SP229</td><td>SP230</td><td>SP231</td></tr> </table>	SP226	SP227	SP228	SP229	SP230	SP231
SP226	SP227	SP228					
SP229	SP230	SP231					
	<table border="1"> <tr><td>SP232</td><td>SP233</td><td>SP234</td></tr> <tr><td>SP235</td><td>SP236</td><td>SP237</td></tr> </table>	SP232	SP233	SP234	SP235	SP236	SP237
SP232	SP233	SP234					
SP235	SP236	SP237					
	<table border="1"> <tr><td>SP238</td><td>SP239</td><td>SP240</td></tr> <tr><td>SP241</td><td>SP242</td><td>SP243</td></tr> </table>	SP238	SP239	SP240	SP241	SP242	SP243
SP238	SP239	SP240					
SP241	SP242	SP243					
	<table border="1"> <tr><td>SP244</td><td>SP245</td><td>SP246</td></tr> <tr><td>SP247</td><td>SP248</td><td>SP249</td></tr> </table>	SP244	SP245	SP246	SP247	SP248	SP249
SP244	SP245	SP246					
SP247	SP248	SP249					

L = 1000mm		L = 2000mm		L = 3000mm	
	SP254		SP254		SP254
	SP255		SP255		SP255
	SP256		SP256		SP256
	SP257		SP257		SP257
	SP258		SP258		SP258
	SP259		SP259		SP259
	SP260		SP260		SP260
	SP261		SP261		SP261
	SP262		SP262		SP262
	SP263		SP263		SP263
	SP264		SP264		SP264
	SP265		SP265		SP265
	SP266		SP266		SP266
	SP267		SP267		SP267
	SP268		SP268		SP268
	SP269		SP269		SP269
	SP270		SP270		SP270
	SP271		SP271		SP271
	SP272		SP272		SP272
	SP273		SP273		SP273
	SP274		SP274		SP274
	SP275		SP275		SP275
	SP276		SP276		SP276
	SP277		SP277		SP277
	SP278		SP278		SP278
	SP279		SP279		SP279
	SP280		SP280		SP280

Vedi capitolo Binario
 Traddel Projector
 See section Traddel
 Projector Track
 Voir chapitre Traddel
 Projector binaire
 Ver capitolo binario
 Traddel Projector
 Siehe kap. Traddel
 Projector Track

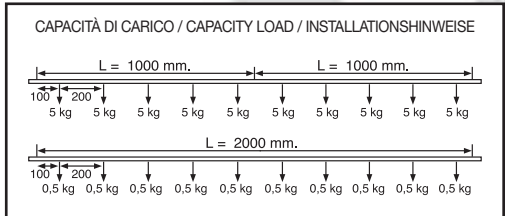



Colore, dinamismo e staticità a portata di mano.
Luce diffusa generata dalle plafoniere fluorescenti in RGB (news Traddel) e luce d'accento emessa dai proiettori Edwin RGB: un connubio eccezionale per catturare l'attenzione creando stupore.

*Colour, dynamism and stillness on hand.
Diffused light generated by the fluorescent RGB (news Traddel) downlights and focused light emitted by the Edwin RGB spotlights: an exceptional combination that captures the attention while generating amazement.*

*Couleur, dynamisme et statisme à portée de la main
Un éclairage diffus généré par des plafonniers fluorescents RGB (news Traddel) et un éclairage d'accent émis par des projecteurs Edwin RGB: une alliance exceptionnelle sachant capturer l'attention du public et provoquer son émerveillement.*

*Color, dinamismo y estaticidad al alcance.
Luz difusa producida por los plafones de techo fluorescentes en RGB (news Traddel) y luz de realce emitida por los proyectores Edwin RGB: una combinación excepcional para llamar la atención asombrando.*

*Farbe, Dynamik und Starrheit stets griffbereit.
Diffuses Licht durch die Leuchtstoff-Deckenleuchten in RGB-Version (Traddel News) und Akzentlicht durch die Scheinwerfer Edwin RGB: eine außergewöhnliche Verbindung, die die Aufmerksamkeit fesselt und Erstaunen hervorruft.*



Edwin



Edwin

Proyector al techo orientable en el eje vertical y horizontal. Provisto de soporte y alimentador.

Auf der vertikalen und horizontalen Achse schwenkbarer Deckenscheinwerfer. Komplett mit Montagebügel und Netzteil.

Proiettore a soffitto orientabile sull'asse verticale ed orizzontale. Completo di staffa ed alimentatore.

Ceiling spotlights adjustable on the horizontal and vertical axes. Complete with bracket and driver.

Projecteur a plafond orientable sur l'axe verticale t sur l'axe horizontal. Fourni avec étrier et alimentateur.

	G	2 Watt 9 LED 87711
Optional 84984	G	2 Watt 12 LED 87712

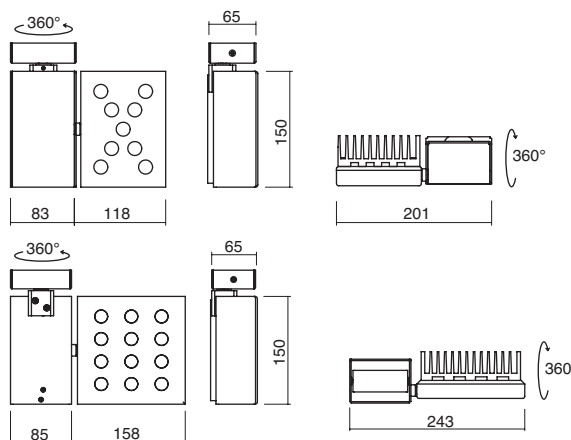

Driver compreso

Driver included
Driver compris
Driver incluido
inklusive Driver



Opticals	code	Colours
30°	30	● C
50°	50	● W ○ N



84984
Optional



INSIDE ceiling

Assoc

- living inside

Assoc

Proiettore da binario orientabile sull'asse verticale ed orizzontale. Completo di adattatore per binario orientabile elettrificato Eurostandard e alimentatore.

Track system floodlight adjustable on vertical and horizontal board. Complete with adapter for Eurostandard electrified track and driver.

Projecteur orientable pour binaire. Orientable sur l'axe verticale et horizontal. Adaptateur pour binaire Eurostandard et alimentateur.

Proyector orientable para sistema binario. Orientable en eje vertical y horizontal. Completo de adaptador para binario electrificado Eurostandard y alimentador.

Von der Schiene aus ausrichtbare Leuchte. Auf vertikaler und horizontaler Achse ausrichtbar. Mit Adapter für elektrische Stromschiene Eurostandard, und Netzgerät.



Driver compreso

Driver included
Driver compris
Driver incluido
inklusive Driver

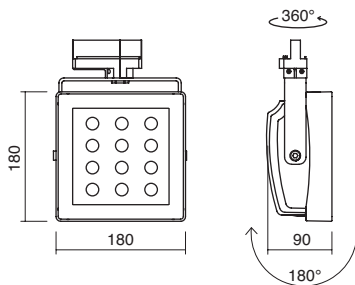

2 Watt

12 LED

87713

G



Accessori per binario vedi catalogo Traddel "Track system accessories"
Track System accessories, see Traddel catalogue
"Track system accessories"
Accessoires pour rail voir catalogue Traddel "Track system Accessoires"
Accesorios para binario (ver catalogo Traddel Track system Accessories)
Elektrifiziertes Schienensystem zubehor im Traddel Katalog "Track system accessories"

Colours	Opticals	code
● C	10°	10
● W	30°	30
● N	50°	50
	70°	70
	120°	12

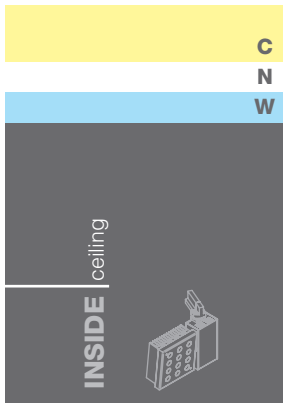

Edwin **MULTICHIP**
Technology



Edwin

Projector orientable en eje vertical y horizontal. Completo de adaptador para binario electrificado Eurostandard, controlador, alimentador y mando a distancia IR.

Von der Schiene Leuchte. Auf vertikaler und horizontaler Achse ausrichtbar. Mit Adapter für elektrische Stromschiene Eurostandard, Steuergerät, Netzgerät und Fernbedienung IR.

Proiettore orientabile sull'asse verticale ed orizzontale. Completo di adattatore per binario elettrificato Eurostandard, centralina di comando, alimentatore e telecomando IR.

Floodlight adjustable on vertical and horizontal board. Complete with adapter for Eurostandard electrified track, controller, driver and IR remote control.

Projecteur orientable sur l'axe verticale et horizontal. Adaptateur pour binare Eurostandard, centrale de commande, alimentateur et télécommande IR inclus.

Driver compreso

*Driver included
Driver compris
Driver incluido
inklusive Driver*

		2 Watt
		18 LED
su binario	G	87706
<i>track system pour binaire par sistema binario aus ausrichtbare</i>		
		2 Watt
		18 LED
a muro	G	87707
<i>wall au mur à la pared Wandleuchte</i>		

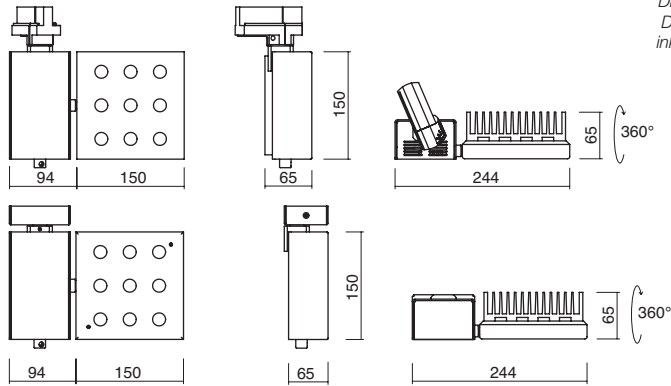

Opticals	code	Colours
50°	50	D



84982
Optional



84984
Optional

Accessori per binario vedi catalogo Traddel "Dynamic Track accessories"
Track System accessories, see Traddel catalogue "Dynamic Track accessories"
Accessoires pour rail voir catalogue Traddel "Dynamic Track Accessoires"

Accesorios para binario (ver catalogo Traddel Dynamic Track Accessories)
Elektrifiziertes Schienensystem zubehor im Traddel Katalog "Dynamic Track accessories"

Emfrid

Proiettore orientabile a soffitto sull'asse verticale ed orizzontale. Completo di centralina di comando, alimentatore e telecomando IR.

Ceiling floodlight adjustable on vertical and horizontal board. Complete with controller, driver and IR remote control.

Projecteur orientable a plafond sur l'axe verticale et horizontal. Centrale de commande, alimentateur et télécommande IR inclus.

Proyector al techo orientable en eje vertical y horizontal. Completo de controlador, alimentador y mando a distancia IR.

Auf der vertikalen und horizontalen Achse schwenkbarer Deckenscheinwerfer. Mit Steuergerät, Netzgerät und Fernbedienung IR.



Driver compreso

Driver included
Driver compris
Driver incluido
inklusive Driver

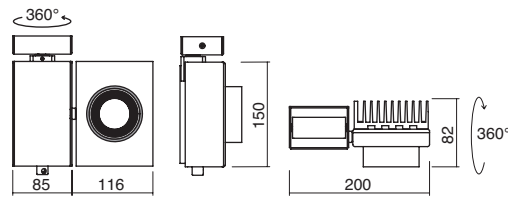

2 Watt

9 LED

88388

G

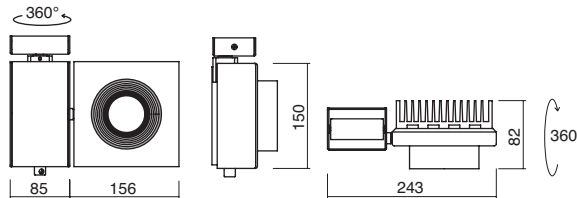

2 Watt

12 LED

88389

G

Optional 84984

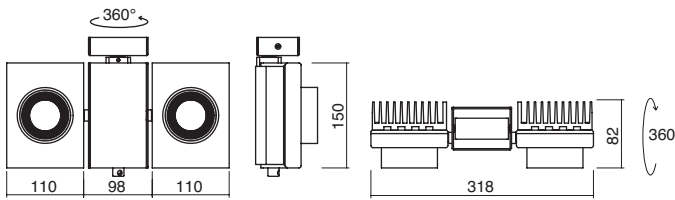

2 Watt

9+9 LED

88390

G

2,000
2,860
4,000
600mA

CE, IP20, F, 850°, 2 WATT, C N W

Colours



Opticals code

70° 70



84984
Optional



84982
Optional

C
N
W

INSIDE ceiling



Emfrid **MULTICHIP**
Technology



Emfrid

Proyector orientable para sistema binario. Orientable en eje vertical y horizontal. Completo de adaptador para binario electrificado Eurostandard, controlador, alimentador y mando a distancia IR.

Von der Schiene aus ausrichtbare Leuchte. Auf vertikaler und horizontaler Achse ausrichtbar. Mit Adapter für elektrische Stromschiene Eurostandard, Steuergerät, Netzgerät und Fernbedienung IR.

Proiettore orientabile da binario sull'asse verticale ed orizzontale. Completo di adattatore per binario elettrificato Eurostandard, centralina di comando, alimentatore e telecomando IR.

Track system floodlight adjustable on vertical and horizontal board. Complete with adapter for Eurostandard electrified track, controller, driver and IR remote control.

Projecteur orientable pour binaire. Orientable sur l'axe verticale et horizontal. Adaptateur pour binaire Eurostandard, centrale de commande, alimentateur et télécommande IR inclus.

Driver compreso

Driver included
Driver compris
Driver incluido
inklusive Driver

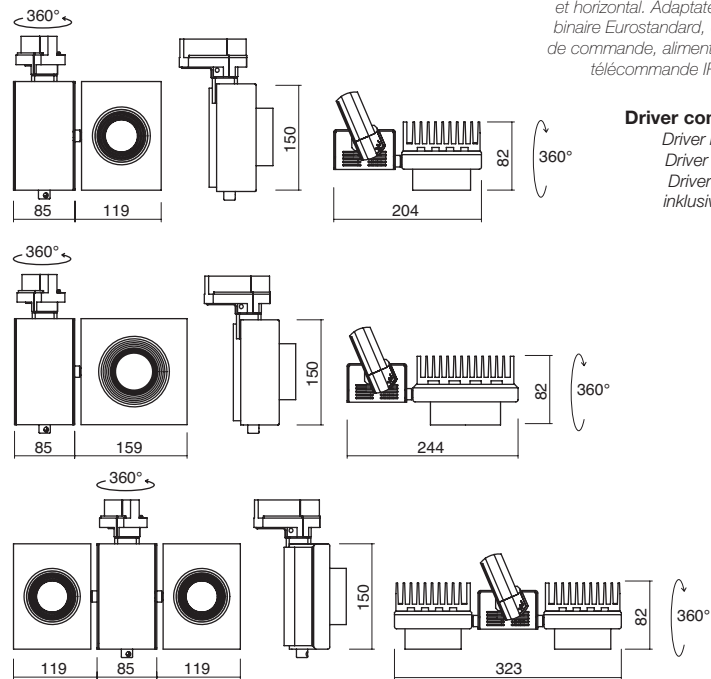

600mA
2,000
2,860
4,000

2 WATT
C N W

Kg

850°

F

IP20

CE

Opticals	code	Colours
70°	70	D



84982
Optional



84984
Optional

Accessori per binario vedi catalogo Traddel
Dynamic Track accessories"
Track System accessories,
see Traddel catalogue
Dynamic Track accessories"
Accessoires pour rail voir
catalogue Traddel "Dynamic
Track Accessoires"
Accesorios para binario (ver
catalogo Traddel Dynamic
Track Accessories)
Elektrifiziertes
Schienensystem zubehor im
Traddel Katalog "Dynamic
Track accessories"



Cornicioni e volta delineati da luce mirata.

Progetto: Wap Park, Atene Grecia
Lighting Design: IFI GROUP

Prodotti: Edwin 12 led 2 Watt

Frames and vault outlined by focused lights.

*Project: Wap Park, Athens Greece
Lighting Design: IFI GROUP*

Products used: Edwin 12 led 2 Watt

Un éclairage orienté traçant le contour des corniches et de la voûte.

*Projet: Wap Park, Athènes Grèce
Design éclairage: IFI GROUP*

Produits: Edwin 12 led 2 Watt

Cornisas y bóveda perfiladas por la luz direccionable

*Proyecto: Wap Park, Atenas, Grecia
Lighting Design: IFI GROUP*

Productos: Edwin 12 led 2 Watt

Umrahungen und Gewölbe werden von gezieltem Licht umrissen

*Projekt: Wap Park, Athen Griechenland
Lighting Design: IFI GROUP*

Produkte: Edwin 12 led 2 Watt

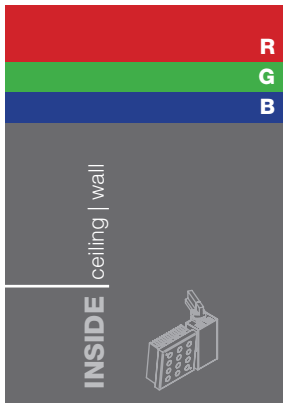

Edwin



Edwin

Projector orientable para sistema binario. Orientable en eje vertical y horizontal. Completo de adaptador para binario electrificado Eurostandard, controlador, alimentador y mando a distancia IR.

Von der Schiene aus ausrichtbare Leuchte. Auf vertikaler und horizontaler Achse ausrichtbar. Mit Adapter für elektrische Stromschiene Eurostandard, Steuergerät, Netzgerät und Fernbedienung IR.

Proiettore orientabile da binario sull'asse verticale ed orizzontale. Completo di adattatore per binario elettrificato Eurostandard, centralina di comando, alimentatore e telecomando IR.

Track system floodlight adjustable on vertical and horizontal board. Complete with adapter for Eurostandard electrified track, controller, driver and IR remote control.

Projecteur orientable pour binaire. Orientable sur l'axe verticale et horizontal. Adaptateur pour binaire Eurostandard, centrale de commande, alimentateur et télécommande IR inclus.

Driver compreso

Driver included
Driver compris
Driver incluido
inklusive Driver

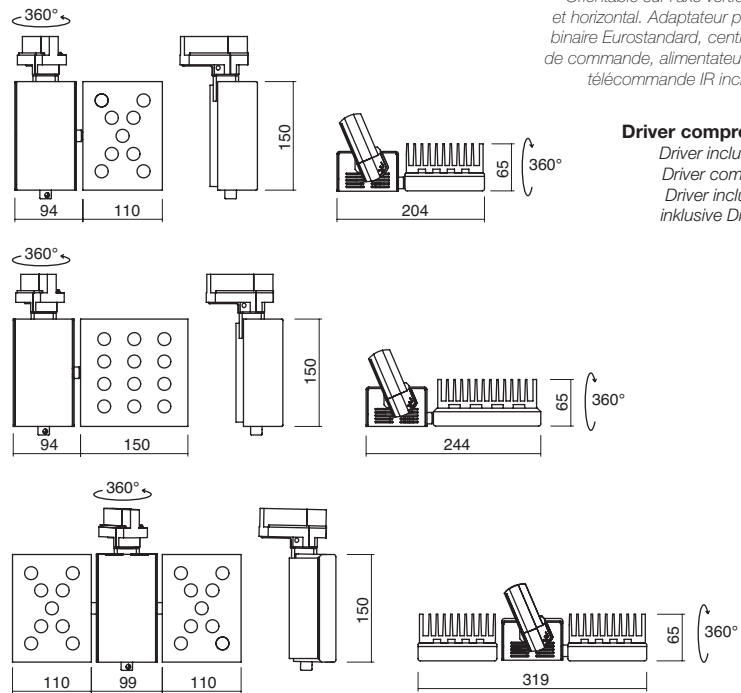

2 Watt RGB

9 LED

87708

G

2 Watt RGB

12 LED

87709

Optional 84984

G

2 Watt RGB

9+9 LED

87710

G



Opticals	code	Colours
30°	30	RGB Z
50°	50	



84982
Optional



84984
Optional

Accessori per binario vedi catalogo Traddel
Dynamic Track accessories
Track System accessories, see Traddel catalogue
Dynamic Track accessories
Accessoires pour rail voir catalogue Traddel "Dynamic Track Accessoires"
Accesorios para binario (ver catalogo Traddel Dynamic Track Accessories)
Elektrifiziertes Schienensystem zubehor im Traddel Katalog "Dynamic Track accessories"

Edwin

Proiettore a soffitto orientabile sull'asse verticale ed orizzontale. Completo di staffa, centralina di comando, alimentatore e telecomando IR.

Ceiling floodlight adjustable on vertical and horizontal board. Complete with adapter for Eurostandard electrified track, controller, driver and IR remote control.

Projecteur orientable a plafond réglable l'axe verticale et horizontal. Étrier, central de commande, alimentateur et télécommande IR Inclus.

Driver compreso

Driver included
Driver compris
Driver incluido
inklusive Driver

Proyector al techo en eje vertical y horizontal. Completo de tijas, controlador, alimentador y mando a distancia IR.

Auf der vertikalen und horizontalen Achse schwenkbarer Deckenscheinwerfer. Mit Bügel, Steuergerät, Netzgerät und Fernbedienung IR.

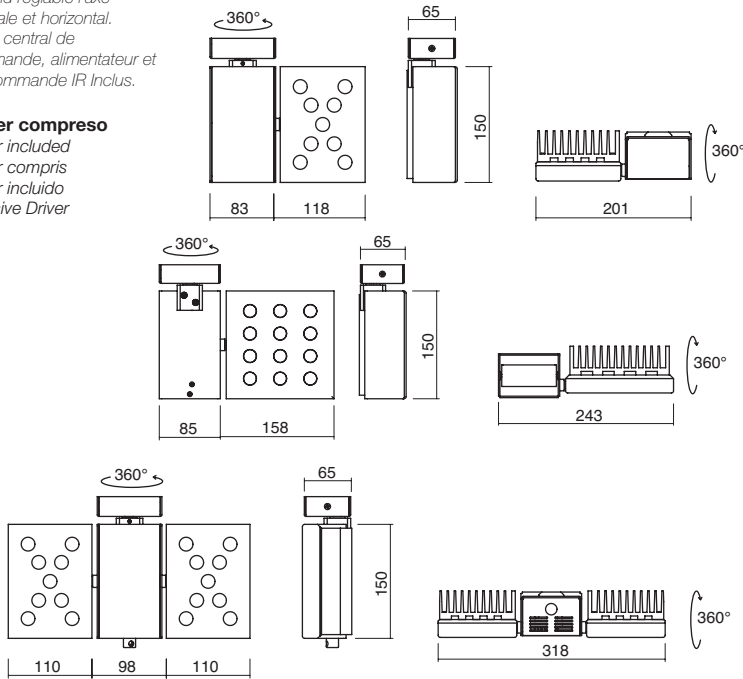

2 Watt RGB

9 LED

87714

G

2 Watt RGB

12 LED

87715

G

Optional 84984

2 Watt RGB

9+9 LED

87716

G



Colours	Opticals	code
RGB Z	30°	30
	50°	50

Accessori per binario vedi catalogo Traddel "Dynamic Track accessories"

Track System accessories, see Traddel catalogue "Dynamic Track accessories"

Accessoires pour rail voir catalogue Traddel "Dynamic Track Accessoires"

Accesorios para binario (ver catalogo Traddel Dynamic Track Accessories)

Elektrifiziertes Schienensystem zubehor im Traddel Katalog "Dynamic Track accessories"



84984
Optional



84982
Optional

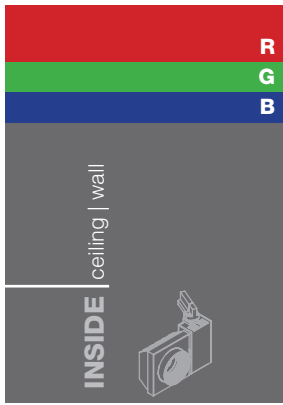

Emfrid **MULTICHIP**
Technology



Emfrid

Multiled projector orientable para sistema binario. Orientable en eje vertical y horizontal. Completo de adaptador para binario electrificado Eurostandard, controlador, alimentador y mando a distancia IR.

Von der Schiene aus ausrichtbare Leuchte, Multiled System. Auf vertikaler und horizontaler Achse ausrichtbar. Mit Adapter für elektrische Stromschiene Eurostandard, Steuergerät, Netzgerät und Fernbedienung IR.

Proiettore con sistema Multiled, orientabile da binario sull'asse verticale ed orizzontale. Completo di adattatore per binario elettrificato Eurostandard, centralina di comando, alimentatore e telecomando IR.

Track system floodlight with Multiled System adjustable on vertical and horizontal board. Complete with adapter for Eurostandard electrified track, controller, driver and IR remote control.

Multiled projecteur orientable pour binaire. Orientable sur l'axe verticale et horizontal. Adaptateur pour binaire Eurostandard, centrale de commande, alimentateur et télécommande IR inclus.

Driver compreso
Driver included
Driver compris
Driver incluido
inklusive Driver

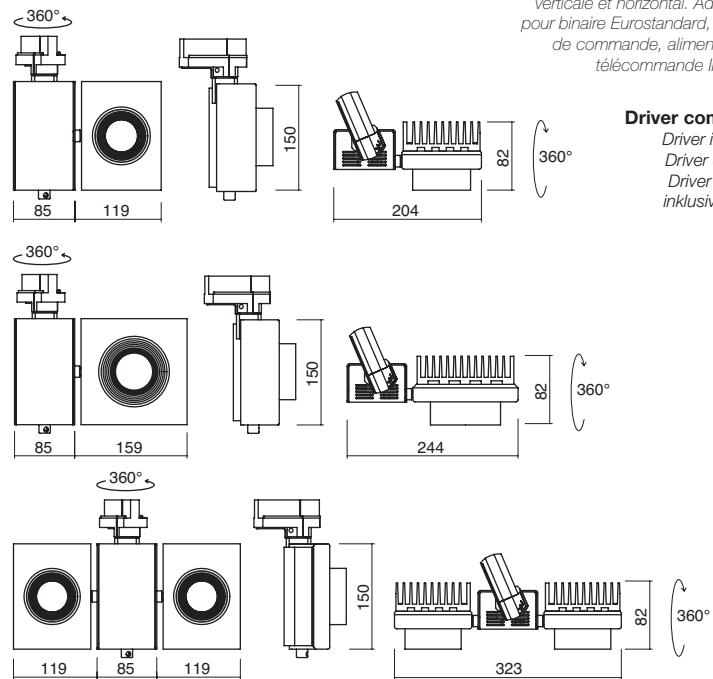

	G	2 Watt	9 LED	88385
Optional 84984	G	2 Watt	12 LED	88386
	G	2 Watt	9+9 LED	88387



Opticals	code	Colours
70°	70	Z



84982
Optional



84984
Optional

Accessori per binario vedi catalogo Traddel
Dynamic Track accessories"
Track System accessories,
see Traddel catalogue
Dynamic Track accessories"
Accessoires pour rail voir
catalogue Traddel "Dynamic
Track Accessoires"
Accesorios para binario (ver
catalogo Traddel Dynamic
Track Accessories)
Elektrifiziertes
Schienensystem zubehor im
Traddel Katalog "Dynamic
Track accessories"

Emfrid

Proiettore orientabile a soffitto sull'asse verticale ed orizzontale. Completo di centralina di comando, alimentatore e telecomando IR.

Ceiling floodlight adjustable on vertical and horizontal board. Complete with controller, driver and IR remote control.

Projecteur orientable a plafond sur l'axe verticale et horizontal. Centrale de commande, alimentateur et télécommande IR inclus.

Proyector al techo orientable en eje vertical y horizontal. Completo de controlador, alimentador y mando a distancia IR.

Auf der vertikalen und horizontalen Achse schwenkbarer Deckenscheinwerfer. Mit Steuergerät, Netzgerät und Fernbedienung IR.



Driver compreso

Driver included
Driver compris
Driver incluido
inklusive Driver

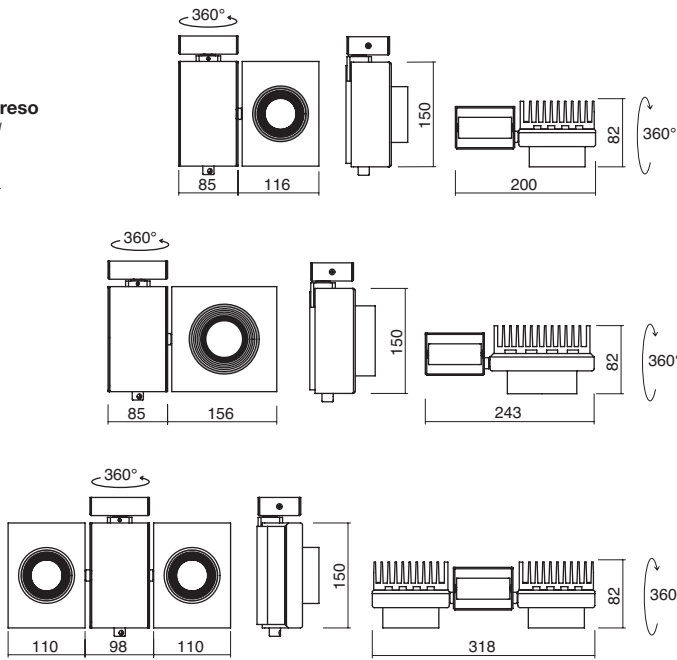

2 Watt

9 LED

88391

G

2 Watt

12 LED

88392

G

Optional 84984

2 Watt

9+9 LED

88393

G



Colours



Opticals code

70°

70

Accessori per binario vedi catalogo Traddel "Dynamic Track accessories"

Track System accessories, see Traddel catalogue "Dynamic Track accessories"

Accessoires pour rail voir catalogue Traddel "Dynamic Track Accessoires"

Accesorios para binario (ver catalogo Traddel Dynamic Track Accessories)

Elektrifiziertes Schienensystem zubehor im Traddel Katalog "Dynamic Track accessories"



84984
Optional



84982
Optional